

Service Manual

Microwave Oven

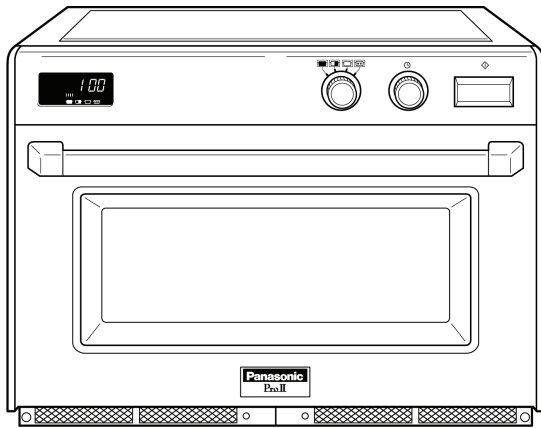

NE-3280
NE-3240
NE-2180
NE-2140

Specifications

	NE-3280	NE-3240	NE-2180	NE-2140	
Power Source :	230-240V 50Hz SINGLE PHASE	400V 2N 50Hz	230-240V 50Hz SINGLE PHASE	400V 2N 50Hz	
Power Requirement :	5.2KW	5.0KW	3.7KW	3.7KW	
High frequency Output :	HIGH	3200W	3200W	2100W	2100W
	MED	1600W	1600W	1050W	1050W
	LOW	340W	340W	340W	340W
	DEF	170W	170W	170W	170W
Frequency :	2450 MHz				
Timer :	NE-3240, NE-2140 60 MINUTES NE-3280, NE-2180 15 MINUTES.....HIGH, MED 60 MINUTES.....LOW, DEF and STAND				
Outside Dimensions :	650 mm (W) × 526 mm (D) × 471 mm × (H)				
Oven Cavity Dimensions :	535 mm (W) × 330 mm (D) × 250 mm × (H)				
Weight :	65 kg		54 kg		
Specifications subject to change without notice.					

⚠ WARNING

This service information is designed for experienced repair technicians only and is not designed for use by the general public. It does not contain warnings or cautions to advise non-technical individuals of potential dangers in attempting to service a product. Products powered by electricity should be serviced or repaired only by experienced professional technicians. Any attempt to service or repair the product or products dealt with in this service information by anyone else could result in serious injury or death.

This service manual covers products for following markets.

When troubleshooting or replacing parts, please refer to the country/area identifications shown below for your applicable product specification.

BPQ.....For United Kingdom EUG.....Continental Europe Countries

WARNING

This products should be serviced only by trained, qualified personnel.

CONTENTS

	Page		Page
1 OUTLINE DIAGRAM	3	14 DISASSEMBLY AND PARTS REPLACEMENT PROCEDURE	19
2 OPERATION PROCEDURE (NE-3280/2180)	5	15 COMPONENT TEST PROCEDURE	22
3 OPERATION PROCEDURE (NE-3240/2140)	8	16 MEASUREMENTS AND ADJUSTMENTS	24
4 SCHEMATIC DIAGRAM NE-3280	9	17 TROUBLESHOOTING GUIDE	25
5 SCHEMATIC DIAGRAM NE-3240	10	18 EXPLODED VIEW AND PARTS LIST	28
6 SCHEMATIC DIAGRAM NE-2180	11	19 PARTS LIST	29
7 SCHEMATIC DIAGRAM NE-2140	12	20 DOOR ASSEMBLE	35
8 WIRING DIAGRAM NE-3280	13	21 ESCUTCHEON BASE ASSEMBLE	36
9 WIRING DIAGRAM NE-3240	14	22 PACKING AND ACCESSORIES	38
10 WIRING DIAGRAM NE-2180	15	23 WIRING MATERIAL	39
11 WIRING DIAGRAM NE-2140	16	24 DIGITAL PROGRAMMER CIRCUIT	43
12 DESCRIPTION OF OPERATING SEQUENCE	16	25 DIGITAL PROGRAMMER CIRCUIT	44
13 CAUTIONS TO BE OBSERVED WHEN TROUBLESHOOTING	18		

1 OUTLINE DIAGRAM

NE-3240,NE-2140

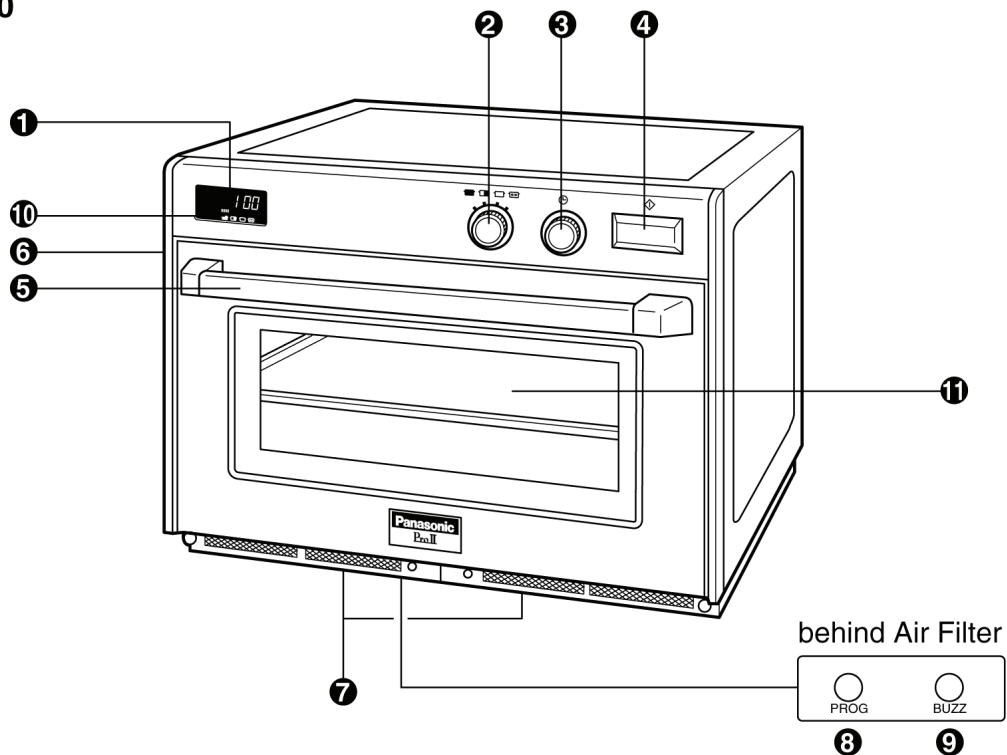



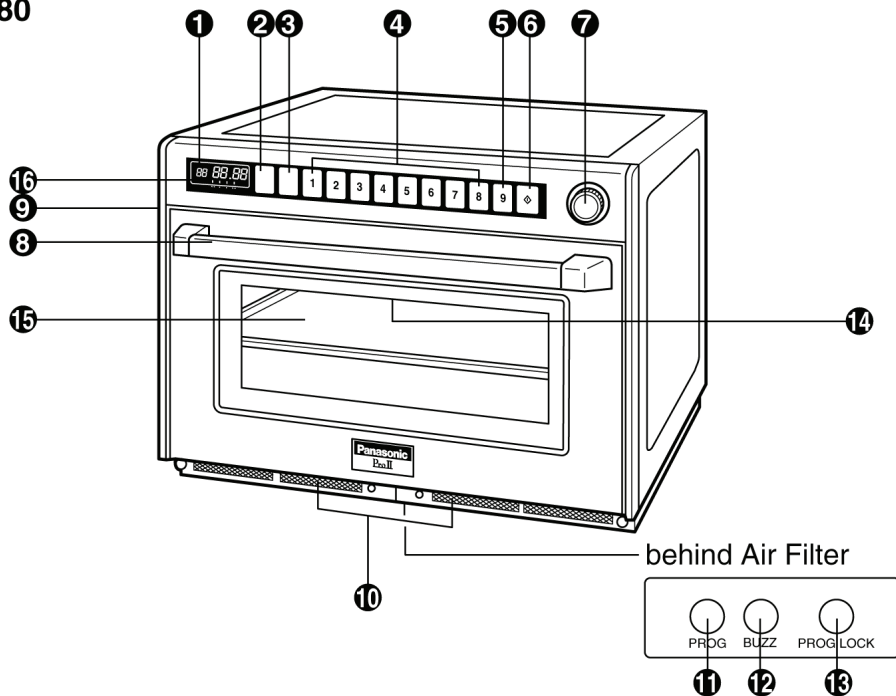

- ① Digital Display Window(see below)
- ② Power Level Selector Dial
- ③ Time Dial
- ④ Start Button
- ⑤ Door Handle

- ⑥ Oven Lamp Cover
- ⑦ Air Filters
- ⑧ Program Entry Switch (behind Air Filters)
- ⑨ Buzzer Switch (behind Air Filters)
- ⑩ Power Level Indicator Display
- ⑪ Middle Shelf

NE-3280,NE-2180













- ① Digital Display Window(see below)
- ② Power Level Selector Pad()
- ③ Memory Shift Pad()
- ④ Memory Pads
- ⑤ Stop Cancel Pad()
- ⑥ Start Pad()
- ⑦ Timer Dial













- ⑧ Oven Lamp Cover
- ⑩ Air Filters
- ⑪ Program Entry Switch (behind Air Filters)
- ⑫ Buzzer Switch (behind Air Filters)
- ⑬ Program Lock Switch (behind Air Filters)
- ⑭ Control Panel

2 OPERATION PROCEDURE (NE-3280/2180)

1. Manual heating for single stage

OPERATION	DISPLAY
1. Plug the power supply cord into wall receptacle.	
2. Open the door. Place a water load in the oven and close the door.	0
3. Tap POWER LEVEL pad () once. (Set to High power)	  0
4. Set the desired heating time by turning the timer dial. (Set to 2 minutes)	  2 00
5. Tap START pad ().	  1 59
6. When the time is up, you hear 3 beeps sound.	 0
7. Open the door and take out the water load. The display goes back to previously setting time.	1  2 00
8. Close the door. 1 minute later, display will return blank.	

2. Manual heating for 2nd or 3rd stage

OPERATION	DISPLAY
1. Follow step 1 to 4 for single stage.	  2 00
2. Tap POWER LEVEL pad () twice. (Set to MED power)	1:  0
3. Set the desired heating time by turning the timer dial. (Set to 1 minute)	1:  1 00
4. Tap START pad (). (1st stage)	 2  59
5. When the 1st stage time is up, you hear 1 beep sound. (2nd stage)	  59
6. When the time is up, you hear 3 beeps sound.	 0
7. Open the door and take out the water load. The display goes back to previously setting time.	1 2  3 00
8. Close the door. 1 minute later, display will return blank.	

NOTE: For a 3rd stage heating cycle, select a further power level and time between steps 3 and 4 above.

3. Memory setting for single stage

OPERATION	DISPLAY
1. Display must be blank before programming can begin. Touch (PROG) pad.	
2. Tap [5] pad. (Set to memory pad 5) NOTE: Previously selected power and time will appear.	
3. Tap [POWER LEVEL] pad ([]) once. (Set to High power)	
4. Set the desired heating time by turning the timer dial. (Set to 1 minute)	
5. Touch (PROG) pad again.	
6. 3 seconds after, the display window will go blank.	

TO PROGRAM MEMORY AREA B: Follow steps 1 above. Touch the Memory Shift pad [A>B] and a small "B" will appear beneath the flashing "PROG".

Touch the memory pad you wish to program, and the previously selected time and power level will appear in the display window.

NOTE: Once the Memory area B has been selected it cannot be changed back to Memory area A. If you do not require Memory area B, cancel it by touching the cancel pad and begin again.

4. Memory setting for 2nd or 3rd stage

OPERATION	DISPLAY
1. Follow steps 1 to 4 for memory setting for single stage.	
2. Tap [POWER LEVEL] pad ([]) twice. (Set to MED power)	
3. Set the desired heating time by turning the timer dial. (Set to 2 minutes)	

OPERATION	DISPLAY
4. Touch Program pad again. Heating time is displayed by adding single and 2nd stage heating time.	
5. 3 seconds after, the display window will become blank.	

NOTE: For a 3rd stage heating cycle, select a further power level and dial in a time, between steps 3 and 4 above.

5. Memory and heating

OPERATION	DISPLAY
1. Plug the power supply cord into wall receptacle.	
2. Open the door. Place a water load in the oven and close the door.	
3. Tap [5] pad.	
4. Tap [START] pad ([]). (1st stage)	
5. (2nd stage)	
6. When the time is up, you hear 3 beeps sounds.	
7. Open the door and take out the water load.	
8. Close the door. Display will return blank after 1 minute.	

NOTE: When program is locked, heating can be started automatically by tapping memory pad.

6. To Read the Cycle Counter

OPERATION	DISPLAY
1. Open the door and close.	0
2. While pressing (BUZZ) switch, press (PROG) switch. The display shows the number of times the oven has been used.	66 66
3. 3 seconds later, the display will go blank.	

NOTE: Total cumulative number includes programming memory heating and manual heating number of times has been used. Cooking times over 99,999 times will be back 0.

7. To Activate Program Lock

OPERATION	DISPLAY
1. Plug the power supply cord into wall receptacle. Do not open the door.	
2. Press and hold (PROG LOCK) switch until the display show "PROG", "P" and "L". (for more than 5 seconds)	PROG
3. Program lock feature now activated.	PROG P L

8. To Release Program Lock

OPERATION	DISPLAY
1. Plug the power supply cord into wall receptacle.	
2. Press and hold (PROG LOCK) switch until the display will show "PROG" and "P". (for more than 5 seconds)	0
3. Program lock feature is now deactivated.	PROG P

9. To Select Beep Tone Options

OPERATION	DISPLAY
1. Plug the power supply cord into wall receptacle.	
2. Press (PROG) switch.	PROG
3. Press (BUZZ) switch.	PROG 3 bE EP 1
4. Select the desired sound loudness level by pressing (BUZZ) switch. Repeated pressing of (BUZZ) switch will lower the loudness and all the way to silent.	PROG 2 bE EP 1
5. Press (PROG) switch again.	PROG 2 bE EP 1
6. 3 seconds later display window will go blank.	

To select length of tone at end of heating cycle there are 2 options.













A. 3 beeps (factory setting)

B. 60 seconds of short beeps.

To set for 60 seconds of short beeps.

OPERATION	DISPLAY
1. Complete steps 1-4 above.	PROG 2 bE EP 1
2. Press (PROG) switch and quickly select the desired tone length by pressing (BUZZ) switch. "1" illuminated 3 beeps. "2" illuminated 60 seconds of beeps.	PROG 2 bE EP 2
3. Press (PROG) switch again.	PROG 2 bE EP 2
4. 3 seconds later, the display will go blank.	

3 OPERATION PROCEDURE (NE-3240/2140)

OPERATION	DISPLAY
1. Plug the power supply cord into wall receptacle.	
2. Open the door. Place a water load and close door.	 
3. Select desired power level if other than  (HIGH) power.	 
4. Set the desired heating time by turning the timer dial.	 
5. Press the start button.	 
6. When the time is up, display will blink "0" until door is opened.	
7. Open the door and remove water load.	 
8. Close the door. 1 minute later, display will go blank.	

Notes:

1. When you press the Start Button with door open, "0" will appear in the display in all cases.
2. Even after setting the heating time you can still change the power level.
3. If you wish to change the heating time during heating, simply adjust the timer to desired minutes and seconds.

4 SCHEMATIC DIAGRAM NE-3280

SCHEMATIC DIAGRAM NE-3280

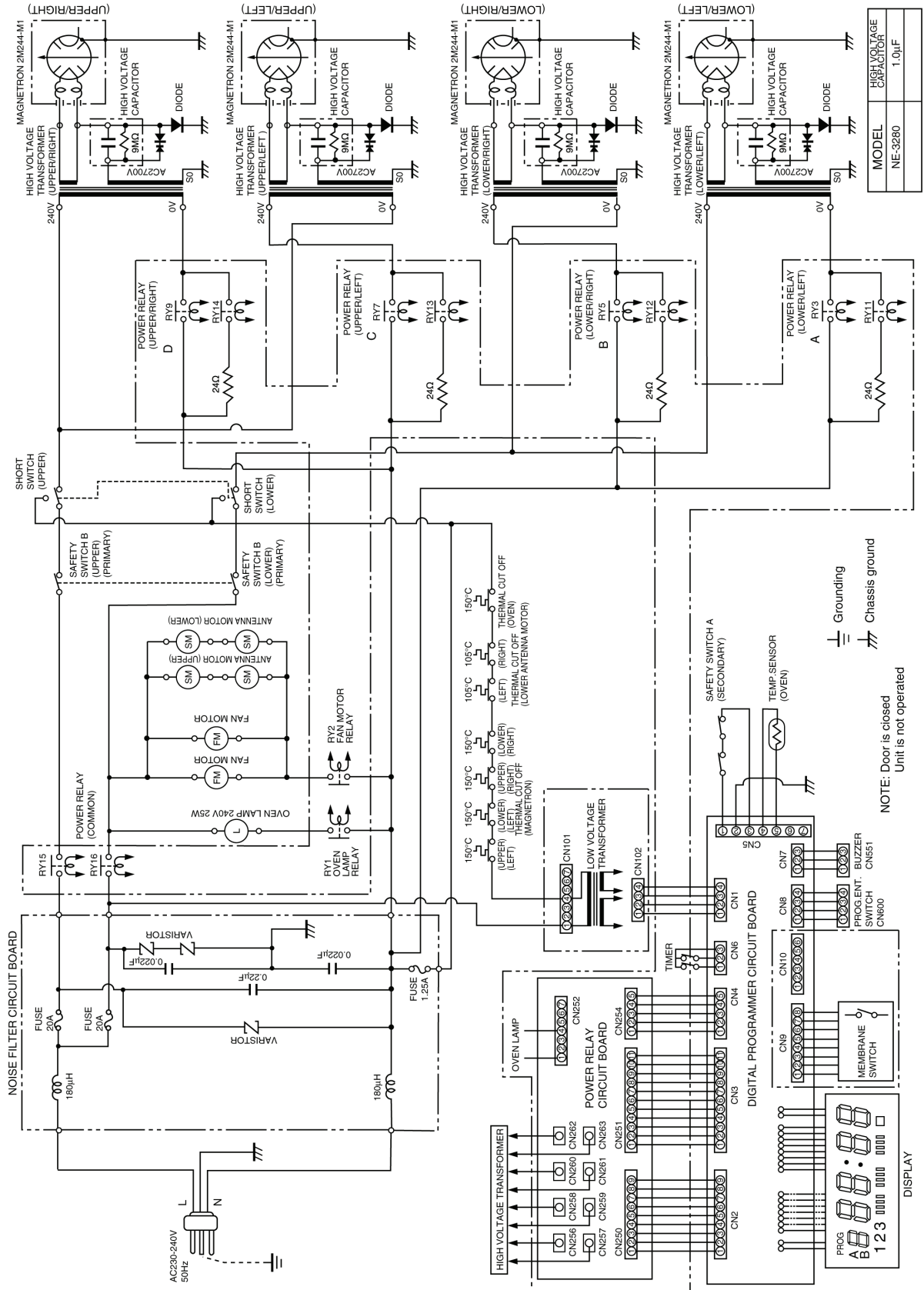

MODEL	NE-3280
HIGH VOLTAGE CAPACITOR	1.0µF

NOTE: Door is closed
Unit is not operated

5 SCHEMATIC DIAGRAM NE-3240

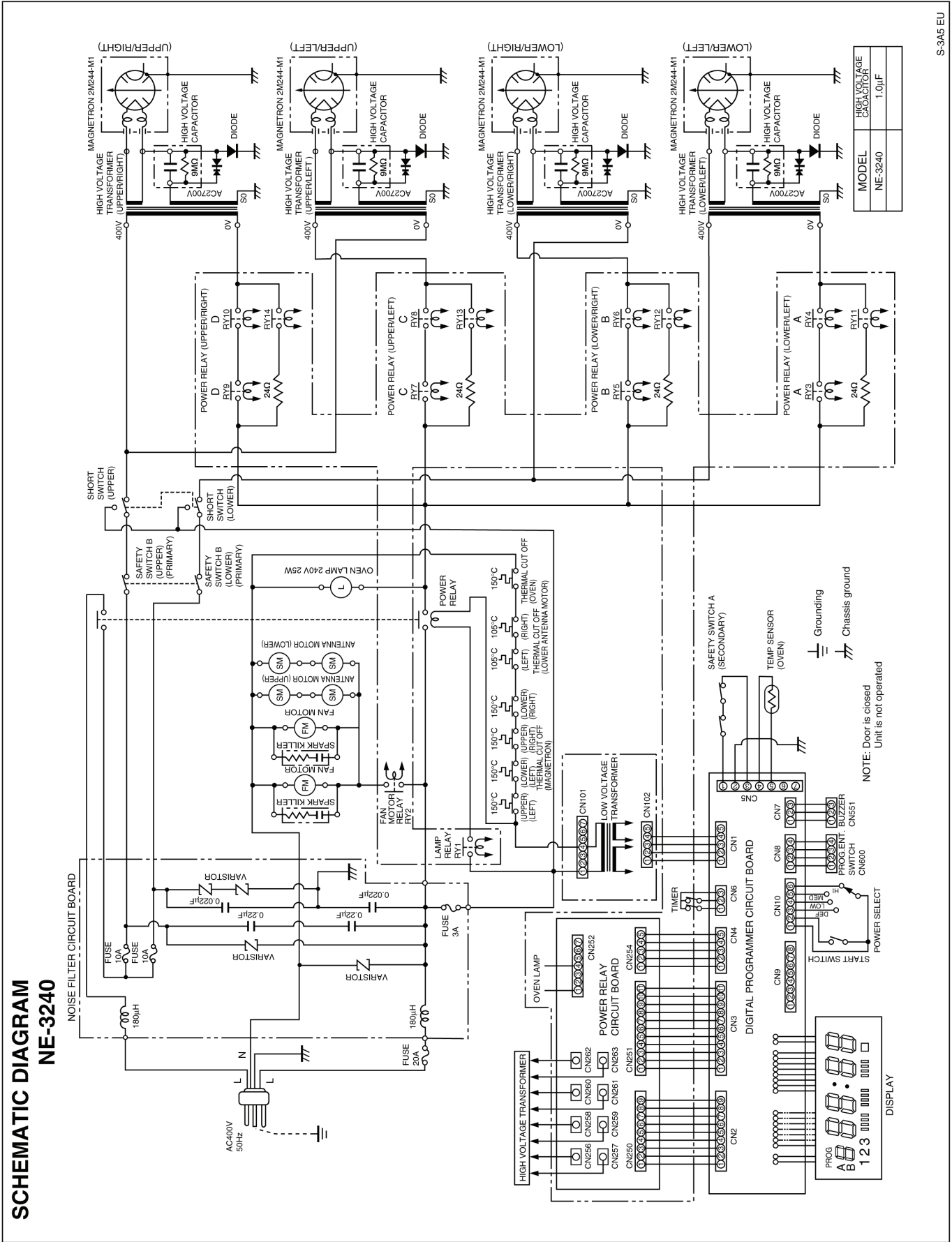

S-3A5 EU

6 SCHEMATIC DIAGRAM NE-2180

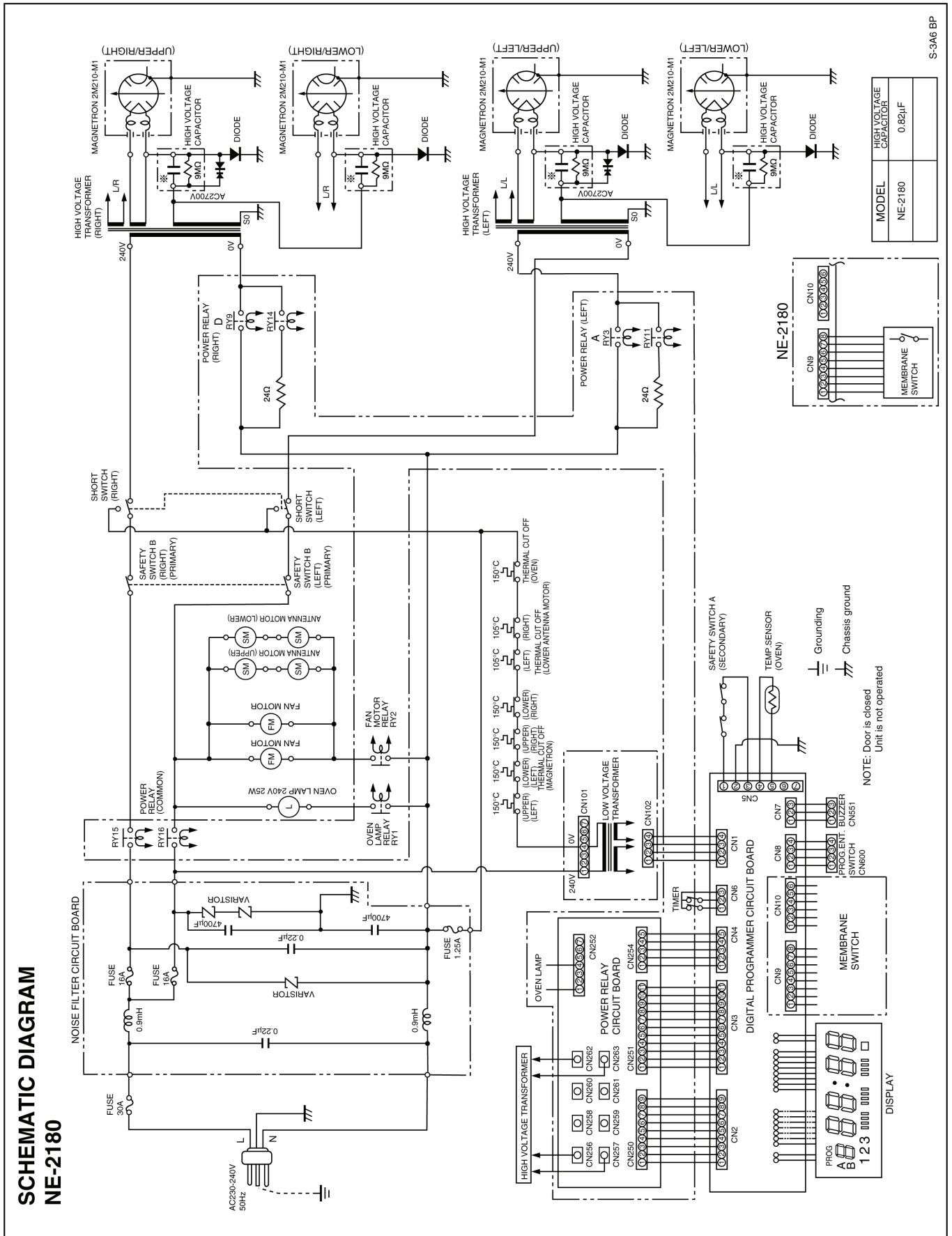

S-3A6 BP

7 SCHEMATIC DIAGRAM NE-2140

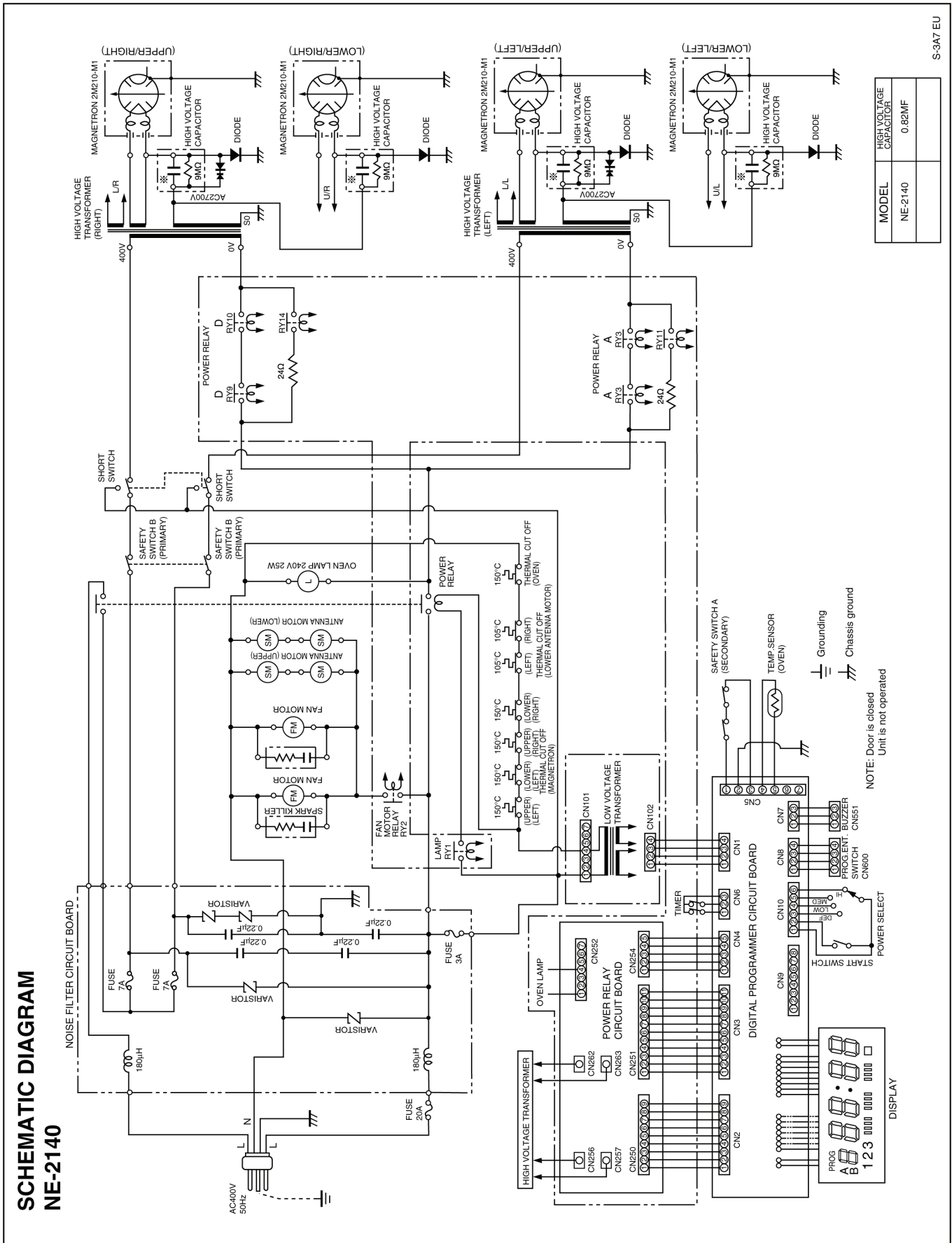

8 WIRING DIAGRAM NE-3280

NOTE: When replacing, check the lead wire colour as shown.

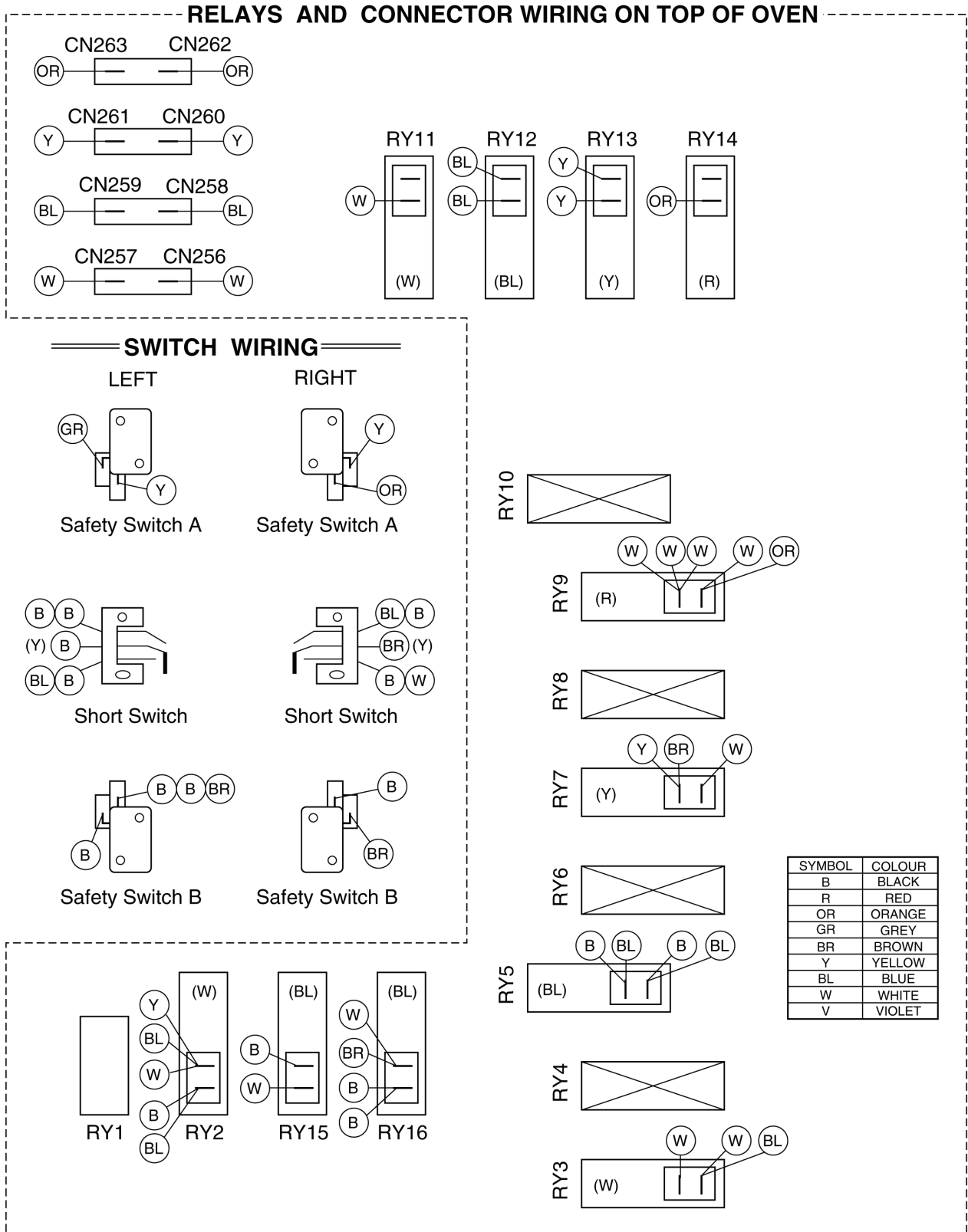

S-3A4 BP
M118

9 WIRING DIAGRAM NE-3240

RELAYS AND CONNECTOR WIRING ON TOP OF OVEN

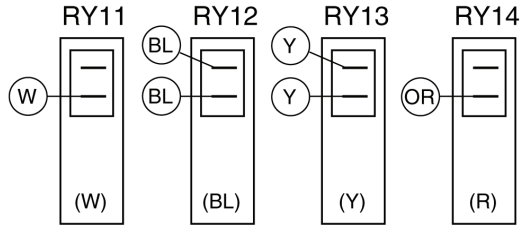
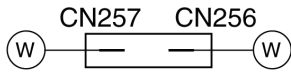
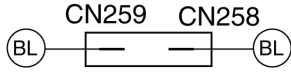
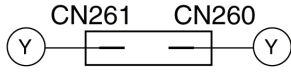
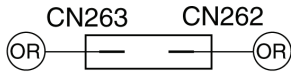

SWITCH WIRING

LEFT

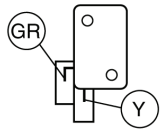

SAFETY SWITCH A

RIGHT

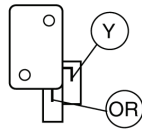

SAFETY SWITCH A

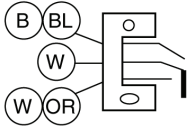

SHORT SWITCH

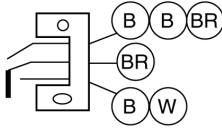

SHORT SWITCH

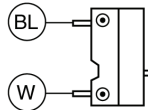

SAFETY SWITCH B

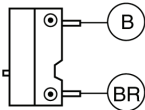

SAFETY SWITCH B

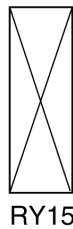
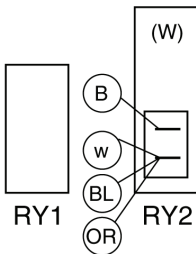

RY15



RY16

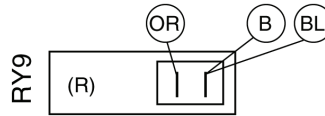

RY9

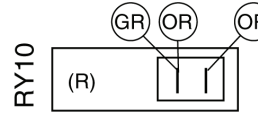

RY10

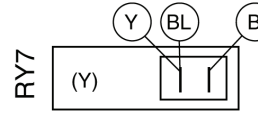

RY7

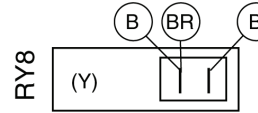

RY8

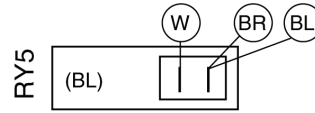

RY5

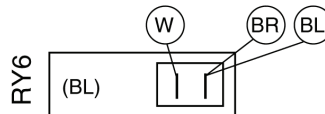

RY6

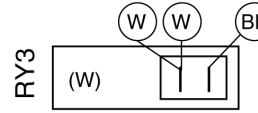

RY3

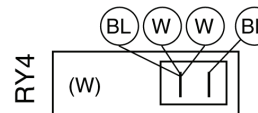

RY4

SYMBOL	COLOUR
B	BLACK
R	RED
OR	ORANGE
GR	GREY
BR	BROWN
Y	YELLOW
BL	BLUE
W	WHITE

S-3A5 EU
M119

10 WIRING DIAGRAM NE-2180

RELAYS AND CONNECTOR WIRING ON TOP OF OVEN

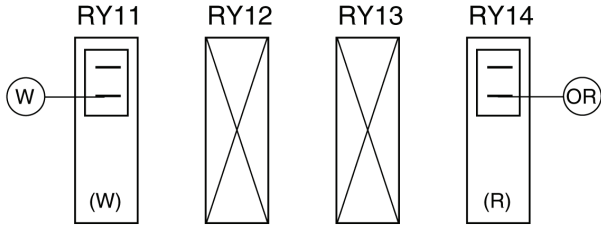
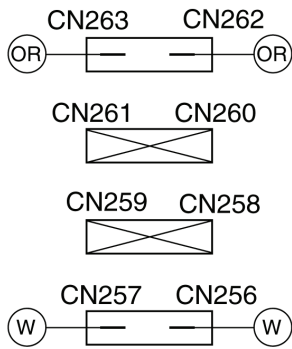

SWITCH WIRING

LEFT

RIGHT

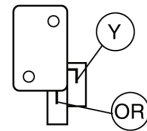
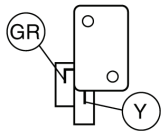

Safety Switch A

Safety Switch A

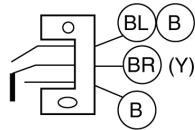
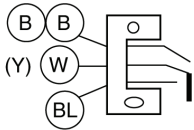

Short Switch

Short Switch

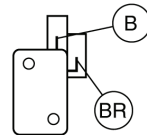
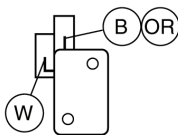

Safety Switch B

Safety Switch B

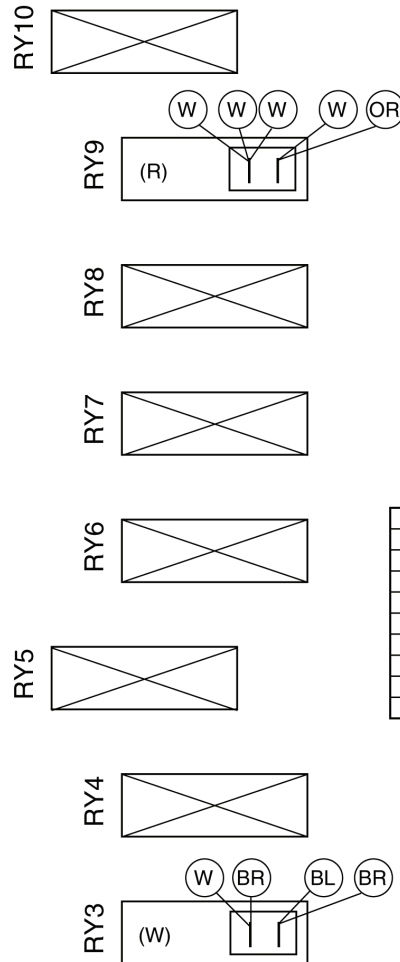
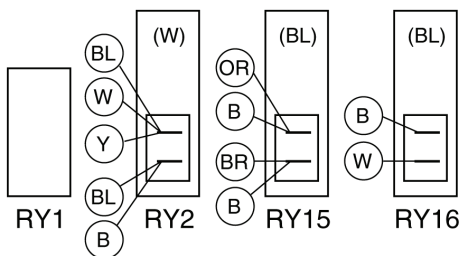

SYMBOL	COLOUR
B	BLACK
R	RED
OR	ORANGE
GR	GREY
BR	BROWN
Y	YELLOW
BL	BLUE
W	WHITE
V	VIOLET

S-3A6 BP
M120

11 WIRING DIAGRAM NE-2140

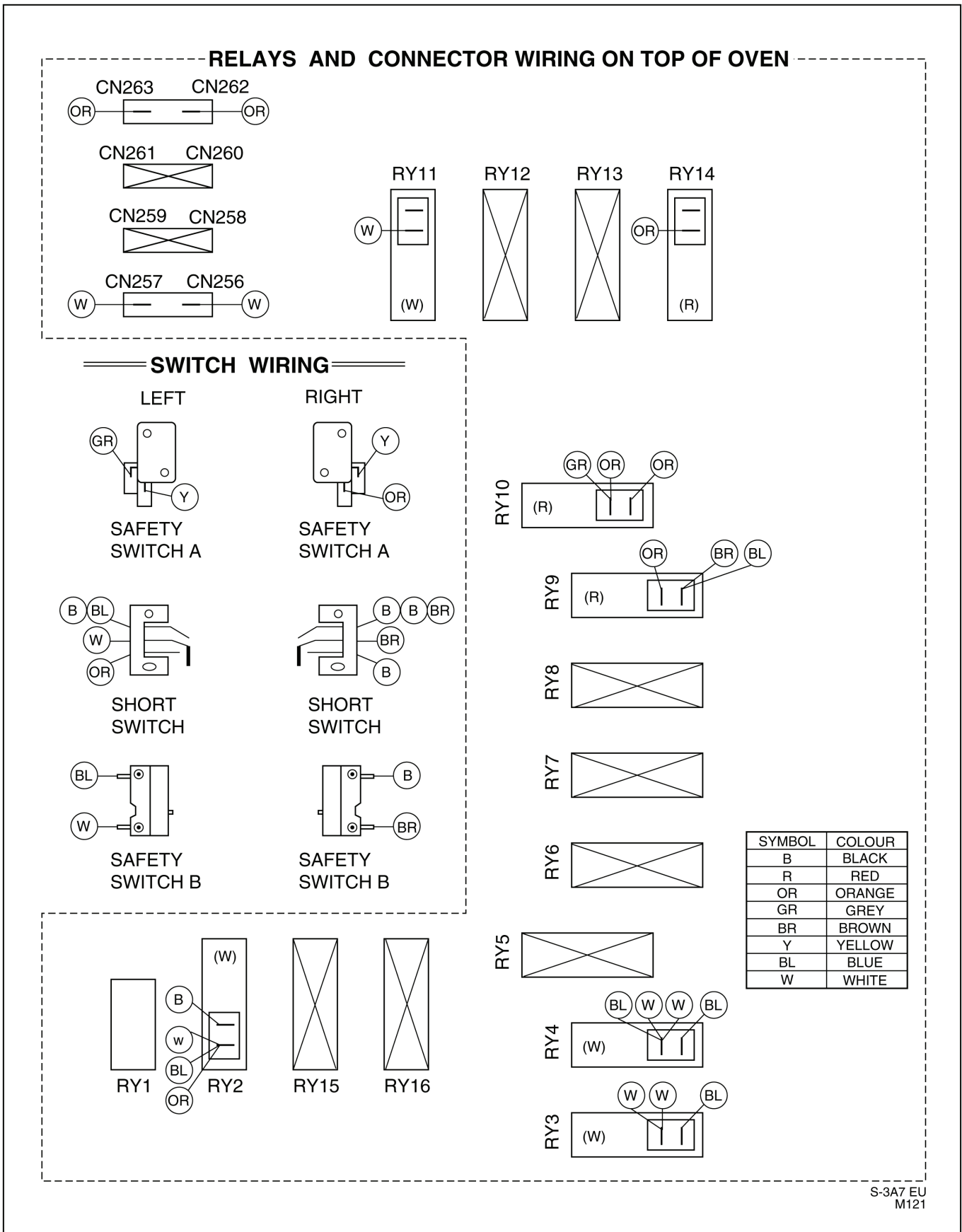

12 DESCRIPTION OF OPERATING SEQUENCE

Variable power cooking control

The coil of power relays are energized intermittently by the digital programmer circuit, when the oven is set at any power selection except for High power position. The digital programmer circuit controls the ON-OFF time of the power relays contacts in order to vary the output power of the microwave oven. The relation between indications on the control panel and the output power of the microwave oven is as

NE-3280,NE-3240

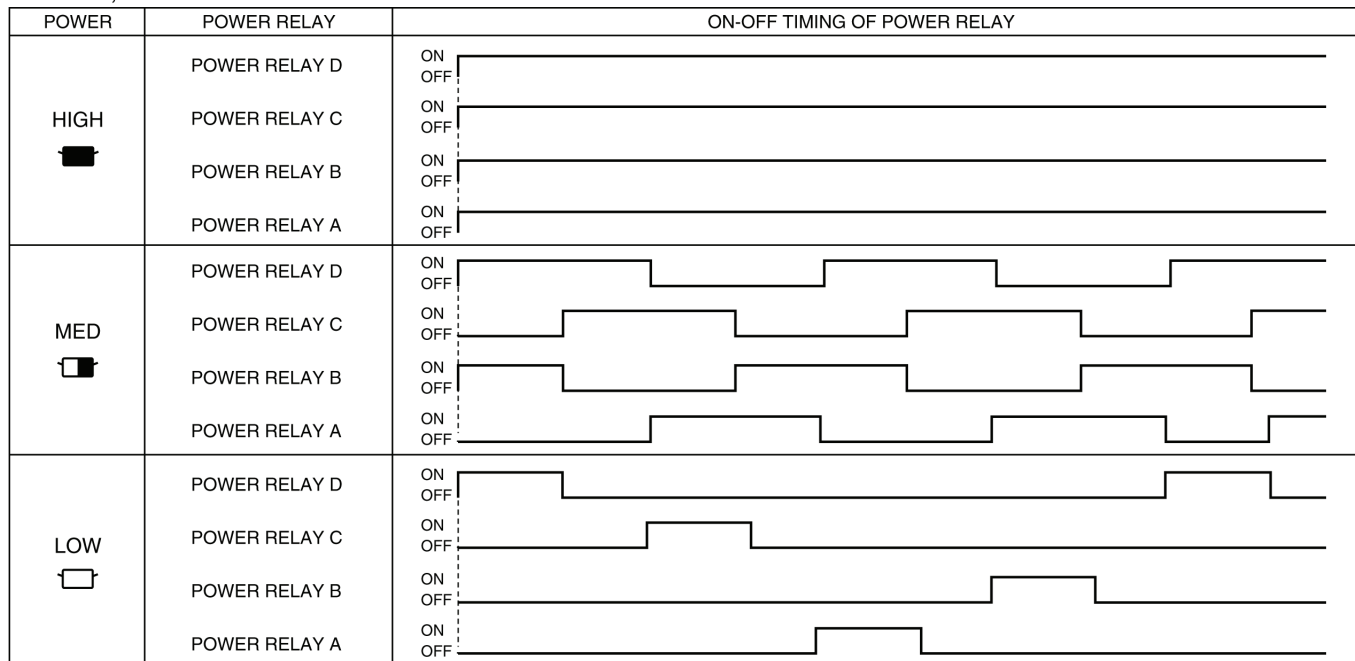

96-029M

NE-2180,NE-2140

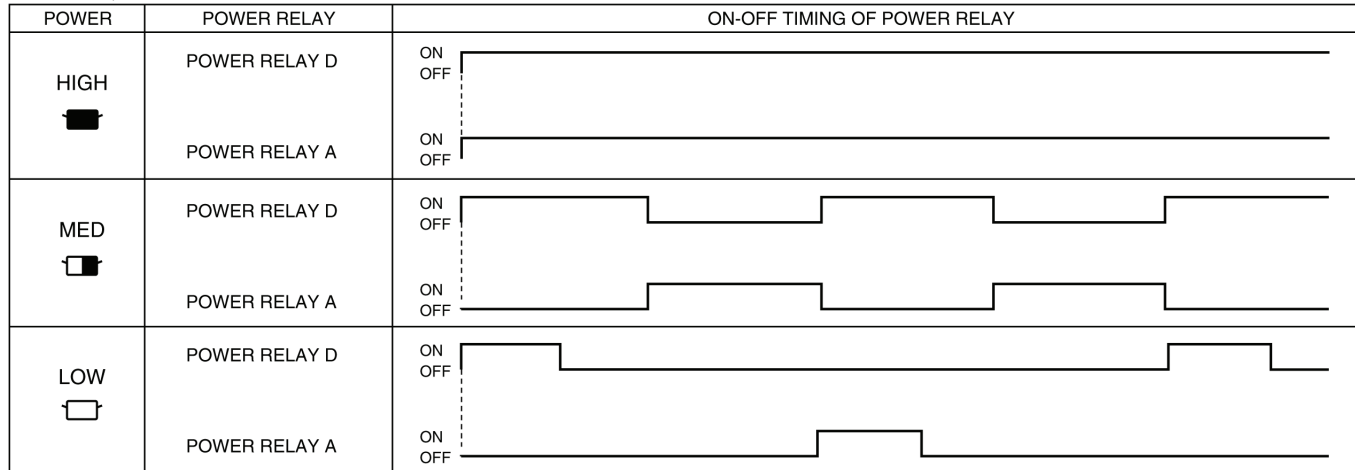

96-030M

shown in table.

NOTE

ON-OFF time of power relays are changed by digital programmer circuit when remaining cooking time or selected cooking time are within 8 minutes at MED, LOW and Defrost cooking mode.

12.1. Defrost control

When defrost power and defrosting time is selected and Start pad is touched:

- 1.The digital programmer circuit (DPC) divides the total defrosting time into 8 equal periods, consisting of four defrosting periods, each followed by a standing period.(See figure)
- 2.During defrosting power periods, power relay ON-OFF time is controlled at Low power mode by DPC.
- 3.During Standing periods, power relay is always open resulting in no microwave power.

NOTE

Defrost time selected is converted into seconds by the DPC but display will show selected time in minutes and seconds as programmed. The total number of seconds is divided into 8 time periods. The remainder (seconds not equally divisible by 8) are added to the last standing time period.

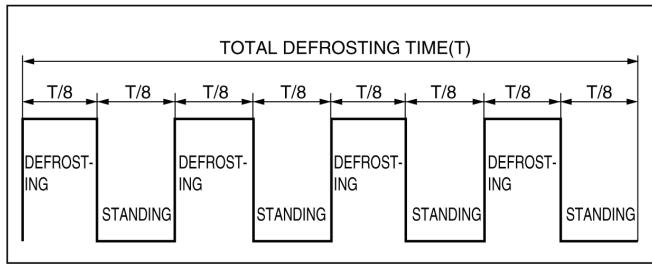

96-004M

13 CAUTIONS TO BE OBSERVED WHEN TROUBLESHOOTING

Unlike many other appliances, the microwave oven is high voltage, high current equipment. Though it is free from danger in ordinary use, extreme care should be taken during repair.

CAUTION

Servicemen should remove their watches whenever working close to or replacing the magnetron.

13.1. Check the earthing

Do not operate on a 2 wire extension cord. The microwave oven is designed to be used in a completely earthed condition. It is imperative, therefore, to make sure it is properly earthed before beginning repair work.

13.2. If the door lock, the door switch, the door seal or the door develops a malfunction, be sure not to operate the oven until complete repairs are made.

If the oven is operated with any of these parts in imperfect condition, hazardous microwave leakage might occur.

WARNING

Never operate the oven until the following are confirmed:

1. The door is tightly closed.
2. There is no broken hinge or door arm.
3. The door seal is not damaged.
4. The door is not bent or warped.
5. There is no other visible damage.

13.3. Warning about the electric charge in the high voltage capacitor.

For about 30 seconds after the oven is turned off, an electric charge remains in the high voltage capacitor. When replacing or checking parts, remove the power plug from the outlet, wait 30 seconds and short the terminal of the high voltage capacitor (terminal of lead wire from diode) to chassis ground with an insulated jumper lead wire or an insulated handle screwdriver to discharge.

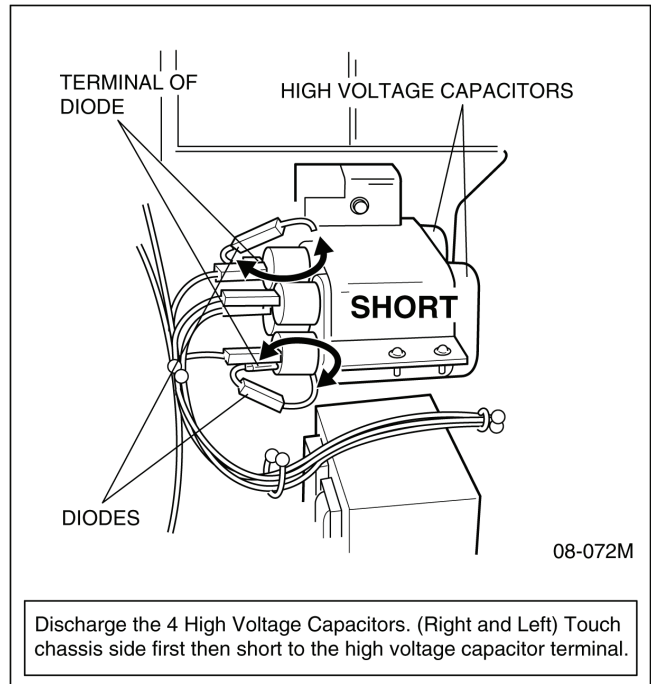

08-072M

Discharge the 4 High Voltage Capacitors. (Right and Left) Touch chassis side first then short to the high voltage capacitor terminal.

Important Note

1. High voltage above 250 volts are existing on following parts during operation.
 - Magnetron
 - High Voltage Transformer
 - High Voltage Diode
 - High Voltage Capacitor

Unusual attention should be paid during repair or troubleshooting of product.
2. If the microwave oven is operated with incorrect installed door hinge or magnetron, it can cause microwave leakage of over 5mW/square centime-ter. Hence it is absolutely necessary to check if magnetron and door hinge are correctly and safely installed after repairs or replacement.

WARNING

Never touch any circuit wiring with your hand nor with an insulated tool during operation.

13.4. When parts must be replaced, always remove the power plug from the outlet, and discharge the high voltage capacitor.

13.5. Confirm after repair

1. After repair or replacement of parts, make sure that the screws of the oven, etc. are neither loose nor missing. Microwave might leak if screws are not properly tightened.
2. Make sure that all electrical connections are tight before inserting the plug into the wall outlet.

13.6. Avoid inserting nails, wire, etc. through holes in unit during operation.

Never insert a wire, nail or any other metal object through the

14 DISASSEMBLY AND PARTS REPLACEMENT PROCEDURE

CAUTION

Serviceman should remove their watches whenever working close to or replacing the magnetron.

14.1. Magnetrons (Upper and Lower)

Upper magnetrons (Right and Left)

1. Discharge electric charge remaining on the high voltage capacitors.
2. Remove the entire rear panel by removing screws as shown in figure.
3. Disconnect all lead wires from magnetron and thermal cutout.
4. Remove the 4 screws holding magnetron.
5. Remove 2 screws holding thermal cutout.
6. Remove the mounting bracket from magnetron and install it on the new magnetron.

Lower magnetrons (Right and Left)

1. Discharge electric charge remaining on the high voltage capacitors.
2. Remove the entire rear panel by removing screws as shown in figure.
3. Disconnect all lead wires from magnetron and thermal cutout.
4. Remove the 4 screws holding magnetron.
5. Remove 2 screws holding thermal cutout.
6. Remove the air guide from magnetron and install it on the new magnetron.

NOTE

To prevent microwave leakage, tighten mounting screws properly making sure there is no gap between the waveguide and the magnetron.

lamp holes on the cavity or any other holes or gaps, because such objects may work as an antenna and cause microwave leakage.

13.7.

CAUTION MICROWAVE RADIATION

Personnel should not be exposed to the microwave energy which may radiate from the magnetron or other microwave generating device if it is improperly used or connected all input and output microwave connections waveguides, flanges, and gasket must be secure. Never operate the device without a microwave energy absorbing load attached. Never look into an open waveguide or antenna while the device is energized.

13.8.

CAUTION

High voltage parts may become uncovered when outer cabinet is removed.

CAUTION

When connecting 2 filament lead wires to the magnetron terminals, be sure to connect the lead wires in the correct position. The lead wire with blue connector should be connected to "FA terminal" and white one should be connected to "F terminal". (See Figure)

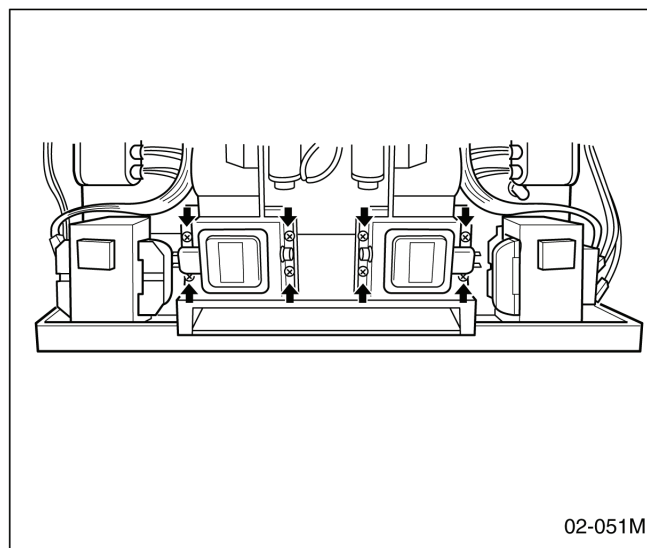

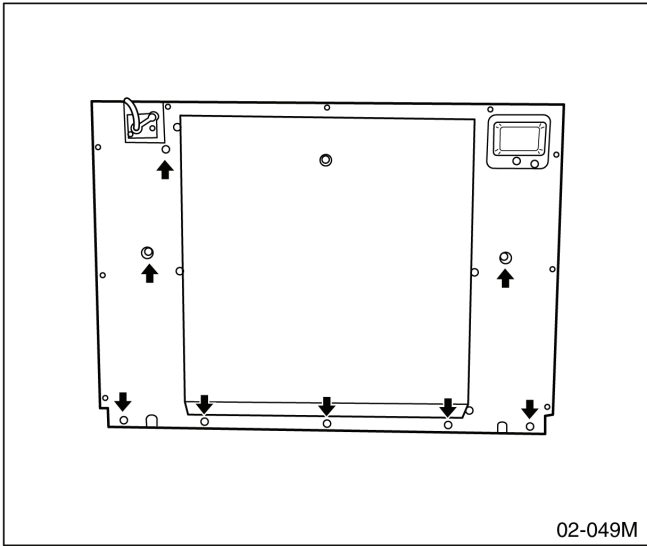

it from main unit then remove connectors.

3. Remove 2 screws holding the D.P.C. board and remove the board by freeing catch hooks.

NOTE

Please use care in handling the power supply P.C.B. and D.P.C. board to avoid damage.

14.3. Low voltage transformer and/or power relays

NOTE

Be sure to ground any static electric charge built up on your body before handling the DPC.

1. Using solder wick or a desoldering tool and 30W soldering iron, carefully remove all solder from the terminal pins of the low voltage transformer and/or power relays.

NOTE

Do not use a soldering iron or desoldering tool of more than 30 watts on DPC contacts.

2. With all the terminal pins cleaned and separated from DPC contacts, remove the defective transformer/power relays and install new transformer/power relays making sure all terminal pins are inserted completely. Resolder all terminal contacts carefully.

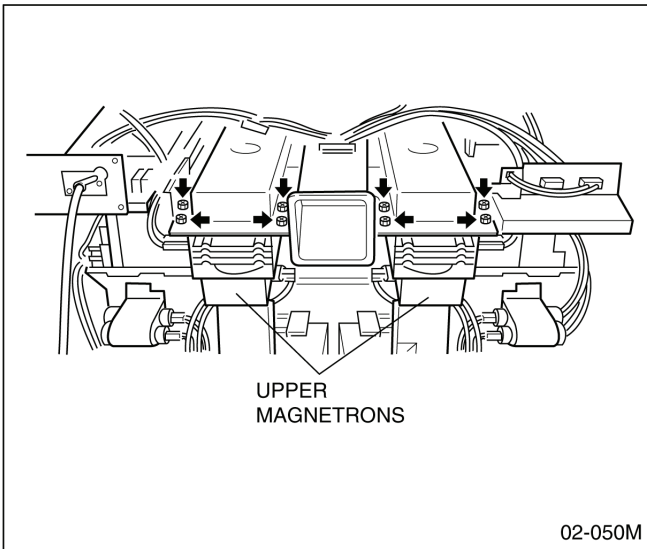

14.4. Disassembly of door assembly

1. Detach the door spring ends from right and left door arms.
2. Remove the arm lever right and left by removing 2 screws each on both sides.
3. Remove the sashes right and left by removing 1 screw each on both sides.
4. By holding the door assembly, remove the right and left sides door hinge pins. The door assembly is now free from the oven.
5. Remove 3 screws holding the door A.
6. Remove the door C by using a flat screwdriver as figure.
7. Remove 4 screws holding door handle.
8. Separate door A and door E.
9. Remove the door arms by removing 1 pin each on both sides.

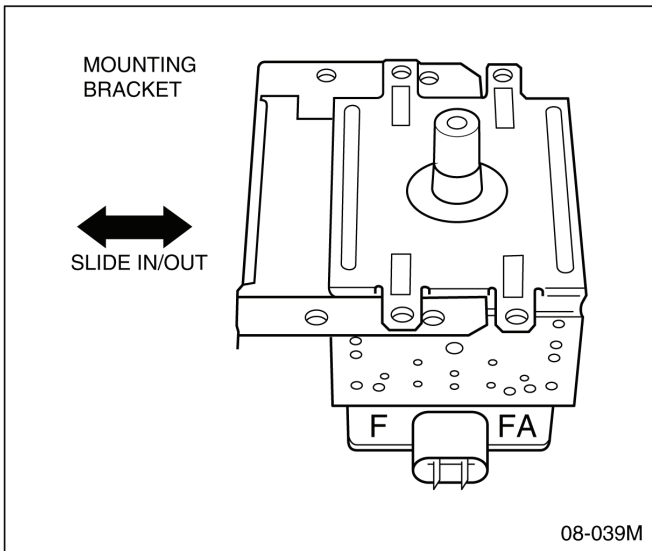

14.2. Digital programmer circuit board

1. Remove grounding screw for membrane switch and D.P.C. ground.
2. Remove 2 screws holding control panel assembly to detach

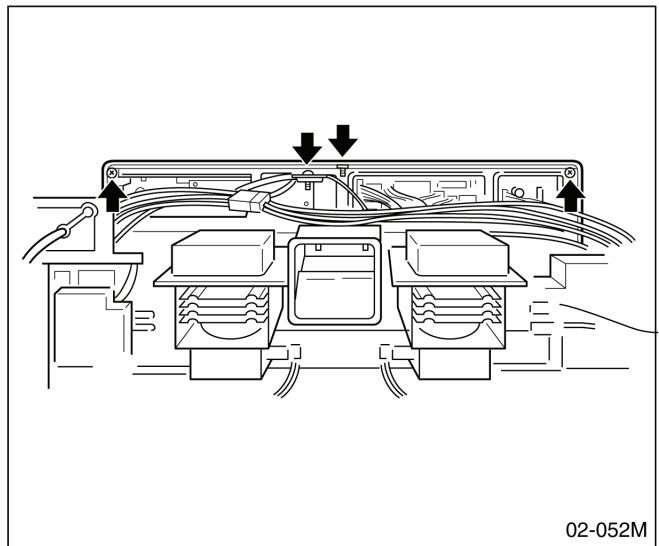

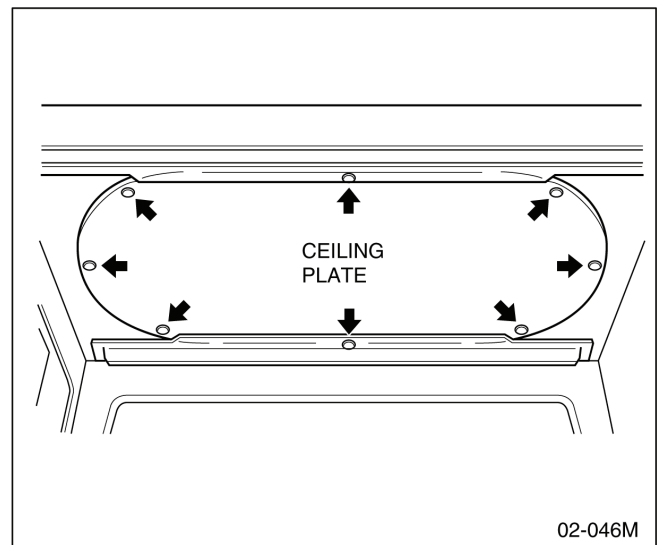
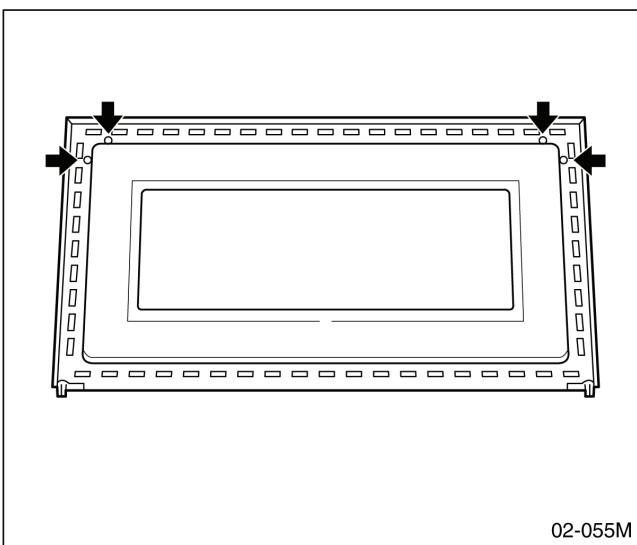
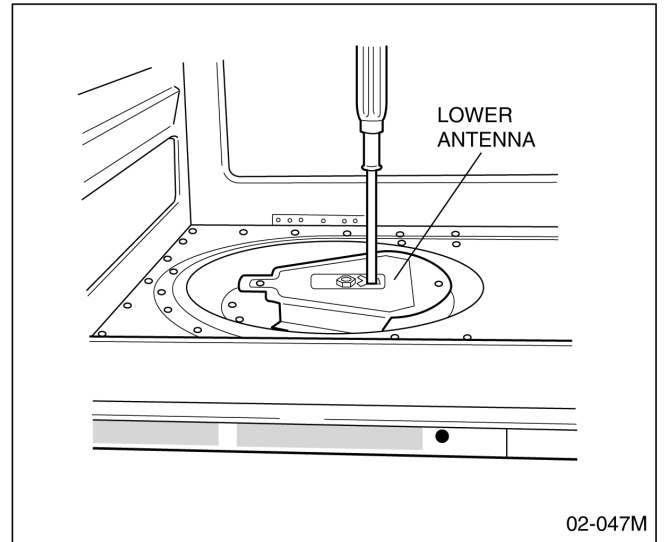
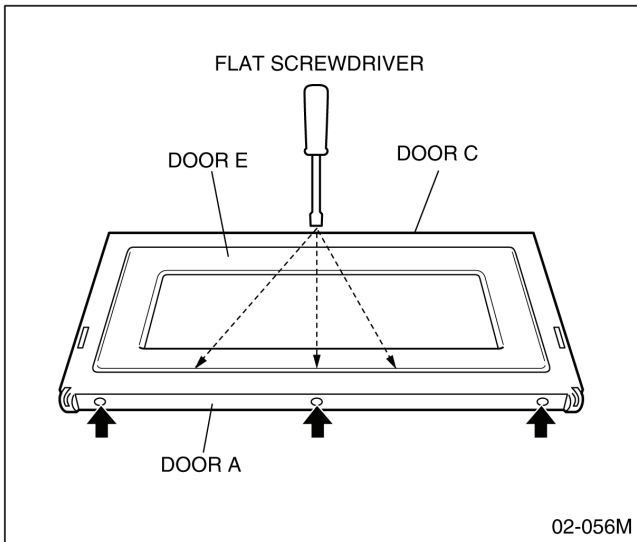

14.5. Upper antenna (Right and Left)

Upper antenna (Right and Left)

1. Remove 8 plastic clips holding ceiling plate and exhaust guides by using flat screwdriver or the like.
2. Remove 2 screws holding upper antenna assy by inserting screwdriver through the opening on the antenna as shown in figure.

14.6. Lower antenna (Right and Left)

Lower antenna (Right and Left)

1. To remove the floor shelf, insert a screwdriver through the openings on the right and left sides of the oven cavity and carefully lift the floor shelf as shown in figure.
2. Remove 2 screws holding lower antenna assy by inserting screwdriver through the opening on the antenna as shown in figure.

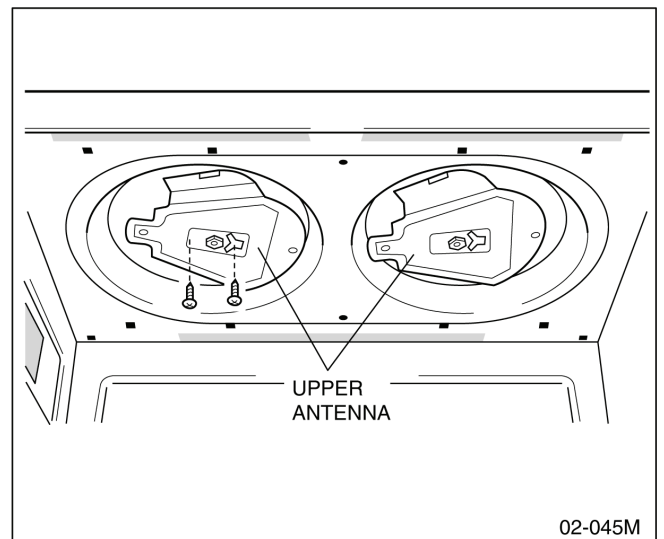

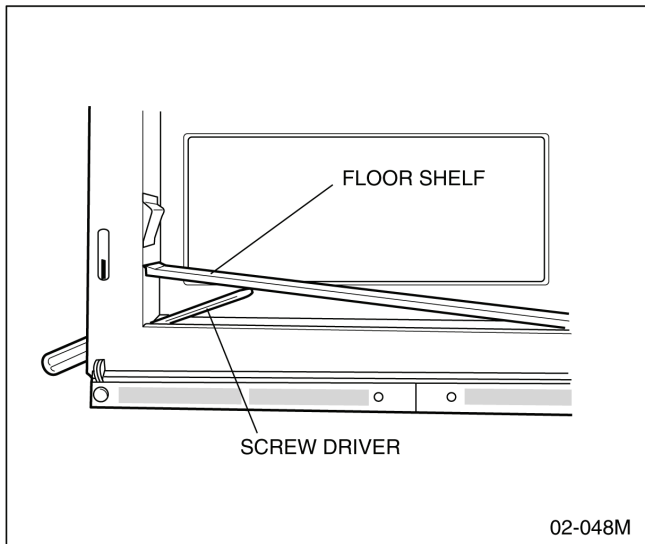

14.7. Replacement of temperature sensor (Thermal protector)

1. Cut 2 lead wires at the top of sensor terminals.
2. Remove 2 screws holding temp sensor and replace with new one.
3. Solder the lead wires securely to the sensor terminals.

14.8. Replacement of antenna motors (upper and lower)

1. The upper antenna motor may be removed by disconnecting the lead wire connectors and removing its 2 mounting screws.

2. To remove the lower antenna motor, carefully place the unit on its left side.
3. Remove the motor cover by removing 2 screws and follow same procedure as for upper antenna.

CAUTION

There are two types of antenna motors. Therefore please replace with correct one as showing below.

Upper Antenna Motor	PART NO.: ANE61446030AP (RATED: 120V)
Lower Antenna Motor	PART NO.: A6144-3280 (RATED: 120V)

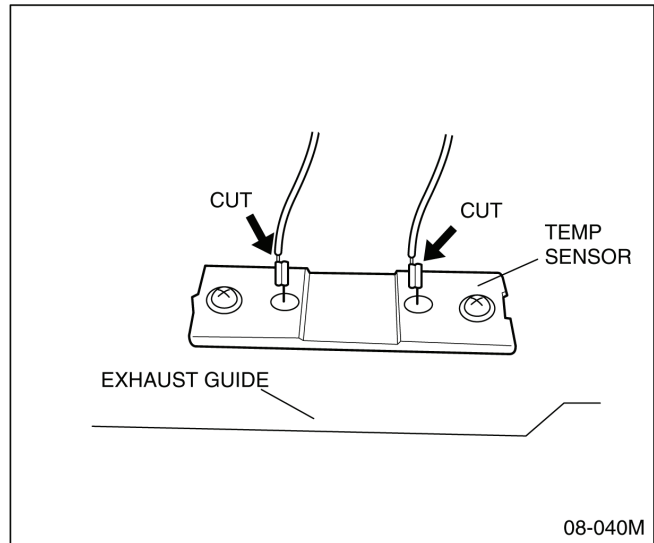

15 COMPONENT TEST PROCEDURE

CAUTION

1. High voltage is present at the high voltage terminal of the high voltage transformer during any cook cycle.
2. It is neither necessary nor advisable to attempt measurement of the high voltage.
3. Before touching any oven components, or wiring, always unplug the oven from its power source and discharge the high voltage capacitor.

15.1. High voltage transformer

1. Remove connections from the transformer terminals and check continuity.
2. Normal (cold) resistance readings should be as follows:
Secondary winding Approx. 40Ω — 100Ω
Filament winding Approx. 0Ω
Primary winding Approx. 0Ω — 3Ω

15.2. High voltage capacitor

1. Check continuity of capacitor with meter on highest OHM scale.
2. A normal capacitor will show continuity for a short time, and then indicate $9M\Omega$ once the capacitor is charged.
3. A shorted capacitor will show continuous continuity.
4. An open capacitor will show constant $9M\Omega$.

5. Resistance between each terminal and chassis should be infinite.

15.3. Magnetron

Continuity checks can only indicate an open filament or a shorted magnetron. To diagnose for an open filament or shorted magnetron.

1. Isolate magnetron from the circuit by disconnecting the leads.
2. A continuity check across magnetron filament terminals should indicate one ohm or less.
3. A continuity check between each filament terminal and magnetron case should read open.

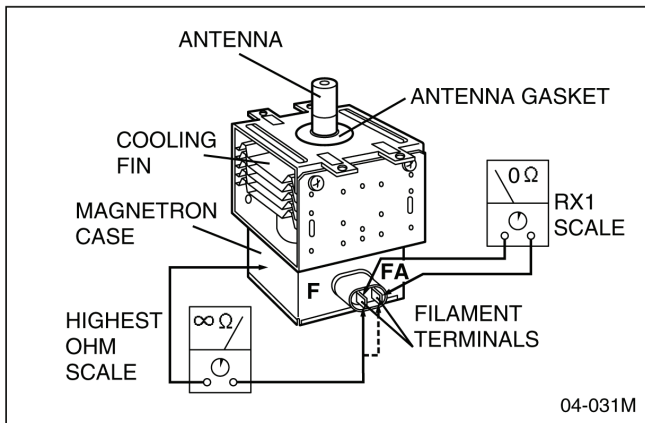
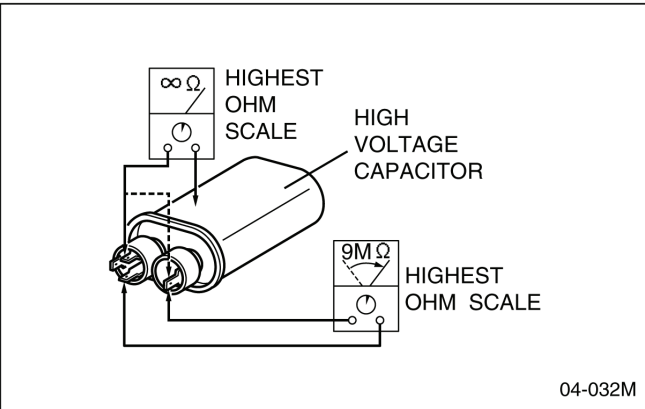
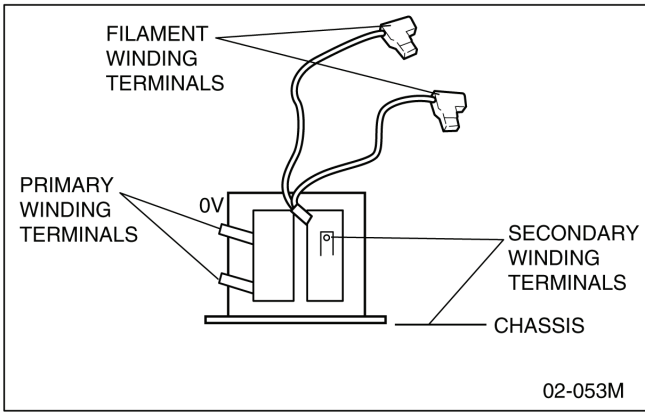

appropriate pad on the key board. The contacts assignment of the respective pads on the key board is as shown in digital programmer circuit.

15.6. Protector diode

1. Isolate the protector diode assembly from the circuit by disconnecting its leads.
2. With the ohmmeter set on the highest resistance scale, measure the resistance across the protector diode terminals. Reverse the meter leads and again observe the resistance reading. A normal protector diode's resistance will be infinite in both directions. It is faulty if it shows continuity in one or both directions.

15.7. Temp sensor (Thermal protector)

A temp sensor is mounted on exhaust guide. Its purpose is to automatically shut off the oven in case the cavity overheats for any reason.

The thermal protector will operate at 257°F(125°C).

The device is connected to the DPC on touch control modes.

When the thermal protector exceeds its temperature it will turn off the power to oven cavity and display will go to reset mode.

The cooking program can be rest after cool-down.

THERMISTOR RESISTANCE VALUE

30K-120K at 10°C-30°C (50°F — 86°F)

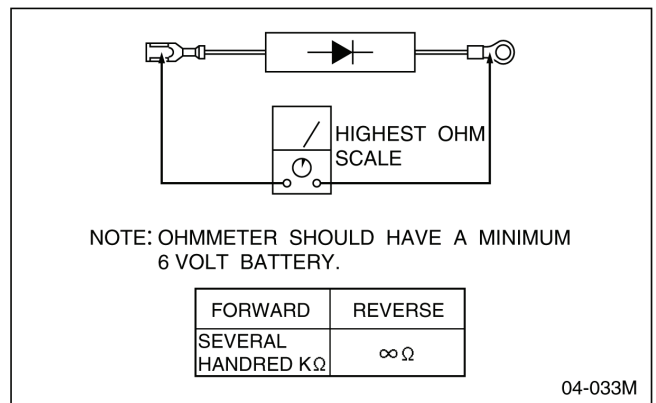

15.4. Diode

1. Isolate the diode from the circuit by disconnecting the leads.
2. With the ohmmeter set on the highest resistance scale, measure the resistance across the diode terminals. Reverse the meter leads and again observe the resistance reading. Meter with 6V, 9V or higher voltage batteries should be used to check the front-to-back resistance of the diode, otherwise an infinite resistance may be read in both directions. A normal diode's resistance will be infinite in one direction and several hundred k in the other direction.

15.5. Membrane key board (Membrane switch assembly)

Check continuity between switch terminals, by tapping an

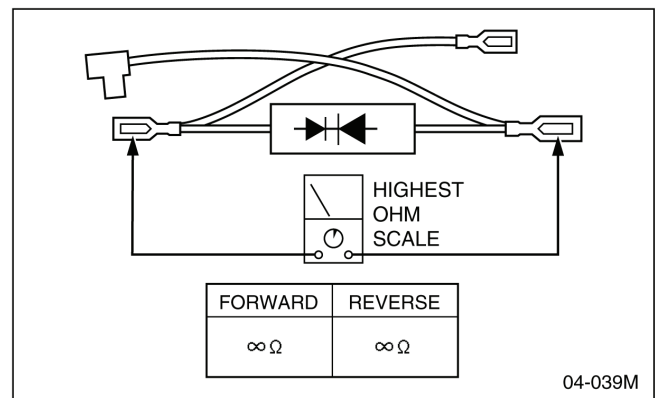

16 MEASUREMENTS AND ADJUSTMENTS

16.1. Adjustment of the safety switch B (Right and Left side)

1. Switch operation

When the door is slightly opened, the safety switch B opens the main circuit. The movement of the door from the closed position to the operation position (shown as liter) of the switch when it opens the main circuit, must maintain within following tolerances.

SAFETY SWITCH B (liter) = 3 mm — 5mm

(When safety switch B opens the main circuit)

NOTE

Make sure that safety switch A turns off prior to the safety switch B when the door is gradually opened.

2. How to adjust safety switch B

Loosen 2 screws which secure the safety switch B bracket to the bracket of the oven assembly and then adjust the safety switch B bracket by moving it to either direction as shown in figure.

16.2. Adjustment of the Short Switch (Right and Left side)

1. When the door is slightly opened, the Short Switch opens the main circuit and closes the contacts for short circuit. The movement of door from its closed position to open position at which the Short Switch contacts open the main circuit (shown as liter) must maintain within 8mm — 11mm and at which the switch contacts close the short circuit should be 20mm — 35mm.

2. How to adjust

Loosen the 2 screws holding the short switch to the short switch bracket, and then adjust the safety switch A by moving it to either direction as shown in figure.

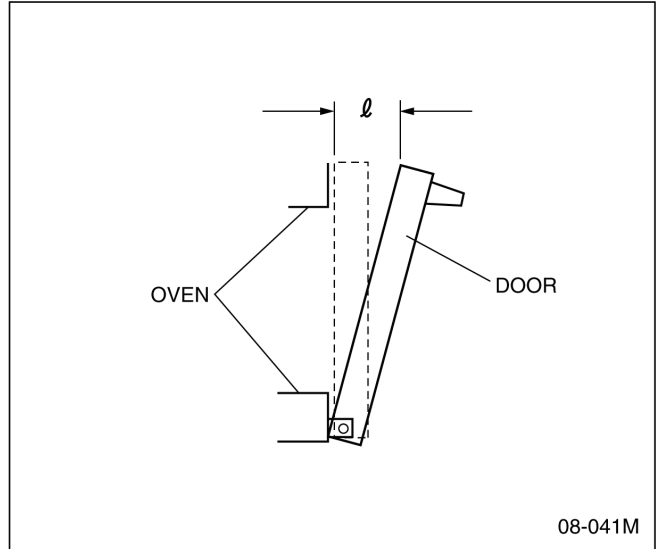
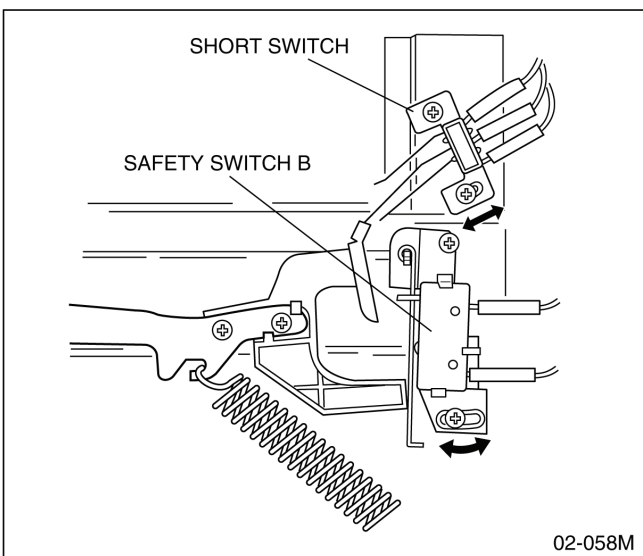

16.3. Adjustment of the safety switch A (Door switch) (Right and Left side)

1. Switch operation

When the door is slightly opened, the contacts of safety switch A opened to give digital programmer circuit the information that the door is opened. The allowable movement of the door from the closed position to the operating position (shown as liter) of the switch when it opens the circuit, is specified as follows;

SAFETY SWITCH A (liter) = 1mm — 3mm

(When safety switch A opens the circuit)

NOTE

Make sure that safety switch A turn off prior to the safety switch B when the door is gradually opened.

2. How to adjust safety switch A

Loosen 2 screws which secure the safety switch A bracket to the bracket of the oven assembly and then adjust the safety switch A bracket by moving it to either direction as shown in figure.

16.4. Measurement of microwave output

The output power of the magnetron can be determined by performing IEC standard test procedures. However, it is possible to test the magnetron by following procedure outlined below. Necessary equipment:

- 1 litre beaker
- Glass thermometer
- Wrist watch or stopwatch

NOTE

Check the line voltage under load to ensure it meets specifications. Low voltage condition will cause a reduction in magnetron output. Temperature readings and heating time, should be as accurate as possible.

Output power performance test procedure.

1. Fill the beaker with exactly one litre of tap water. Stir the water using the thermometer and note the temperature. (Record as T1)
2. Place the beaker in the center of cook plate. Set the oven for High power and heat for exactly one minute.
3. After completion of the heating cycle, stir the water again with the thermometer and note the temperature. (Record as T2)

The normal temperature rise (T2 — T1) at High power position for each models is as shown in following table.

Model	Temperature Rise (1 liter — 1 Min.)
NE-3280 NE-3240	Min. 27.4°C
NE-2180 NE-2140	Min. 18°C

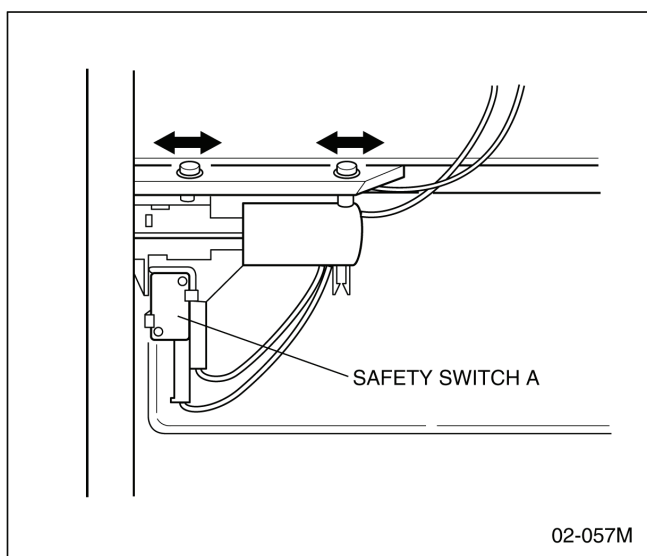
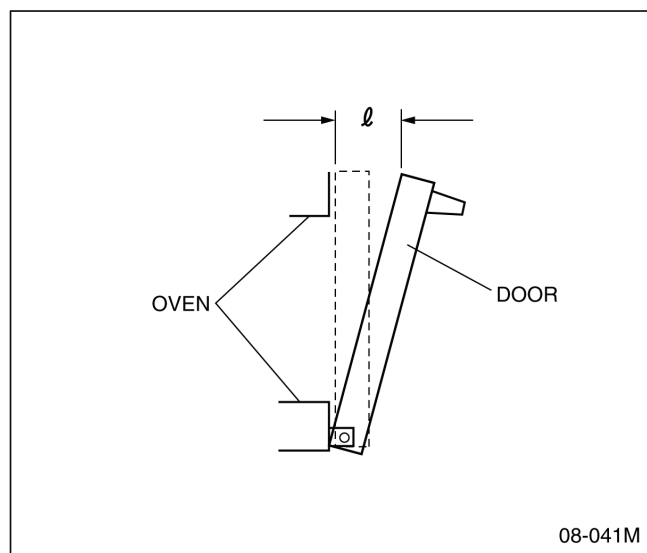

17 TROUBLESHOOTING GUIDE

CAUTION

1. Check grounding before checking for trouble.
2. Be careful of high voltage circuit.
3. Discharge high voltage capacitor.
4. When checking the continuity of the switches or the high voltage transformer, disconnect one lead wire from these parts and then check continuity with the AC plug removed. To do otherwise may result in a false reading or damage to your meter.
When disconnecting a plastic connector from a terminal, you must hold the plastic connector instead of the lead wire and then disconnect it, otherwise lead wire may be open or the connector cannot be removed.
5. Be sure to ground any static electric charge built up in your body, before handling the D.P.C.
6. A 230-240V/400V AC is present at the shaded area () of the power supply circuit board (Terminals of power relays and primary circuit of low voltage transformer). When troubleshooting, be cautious of possible electrical shock hazard.

First of all operate the microwave oven following the correct operating procedures described on pages 3 of this service manual in order to find the exact cause of any trouble.

NOTE

If the unit shows faulty symptom as shown below, check the parts listed in possible cause column depending on failure indication e.g. F81, F82 in the display.

[TROUBLE] Oven does not operate at all or oven does not start cooking. NE-3280, NE-3240

DISPLAY	CONDITIONS	POSSIBLE CAUSE	TIMING OF FAILURE INDICATION
F33	Open temperature sensor (exhaust)	1. Temperature sensor failure 2. Digital programmer circuit failure 3. Loose connector CN5	It is appeared when failure occurred.

DISPLAY	CONDITIONS	POSSIBLE CAUSE	TIMING OF FAILURE INDICATION
F34	Short temperature sensor (exhaust)	1. Temperature sensor failure 2. Digital programmer circuit failure	It is appeared when failure occurred.
F44		1. Shorted power select switch 2. Shorted membrane switch	It is appeared 2 minutes after failure occurred.
F01 (With continuous beep sounds)	Exhaust temperature exceeds 120°C	1. Burning food in the oven due to over cook	It is appeared when exhaust temperature exceeds above 120°C.
F03	Input voltage exceed + 12.5%	1. Increase in power source voltage	It is appeared when the unit is plugged in. Note that it returns normal operation mode by tapping the RESET pad ().
F04	Input voltage is less than — 12.5%	1. Decrease in power source voltage	It is appeared when the unit is plugged in. Note that it returns normal operation mode by tapping the RESET pad ().
F05	Memory failure	1. Digital programmer circuit failure	
No display	1.25/3A fuse blown	1. Switch failure (short switch) 2. Low-Voltage transformer failure	
No display	1.25/3A fuse is OK	1. Thermal cutout failure 2. Low voltage transformer failure 3. Digital programmer circuit failure	
F81	No voltage supply to high voltage trans. (lower/left)	1. Relay failure RY-3 (A) 2. Loose connector CN256, CN257 3. Digital programmer circuit failure	It is appeared when failure occurred.
F82	No voltage supply to high voltage trans. (lower/right)	1. Relay failure RY-5 (B) 2. Loose connector CN258, CN259 3. Digital programmer circuit failure	It is appeared when failure occurred.
F83	No voltage supply to high voltage trans. (upper/left)	1. Relay failure RY-7 (C) Loose connector CN260, CN261 2. Digital programmer circuit failure	It is appeared when failure occurred.
F84	No voltage supply to high voltage trans. (upper/right)	1. Relay failure RY-9 (C) Loose connector CN262, CN263 2. Digital programmer circuit failure	It is appeared when failure occurred.
F86	Shorted contacts of RY-3	1. Replay failure RY-3 (A) 2. Digital programmer circuit failure	It is appeared when failure occurred.
F87	Shorted contacts of RY-5	1. Replay failure RY-5 (B) 2. Digital programmer circuit failure	It is appeared when failure occurred.
F88	Shorted contacts of RY-7	1. Replay failure RY-7 (C) 2. Digital programmer circuit failure	It is appeared when failure occurred.
F89	Shorted contacts of RY-9	1. Replay failure RY-9 (D) 2. Digital programmer circuit failure	It is appeared when failure occurred.

[TROUBLE]Oven does not operate at all or oven does not start cooking. NE-2180, NE-2140

DISPLAY	CONDITIONS	POSSIBLE CAUSE	TIMING OF FAILURE INDICATION
F33	Open temperature sensor (exhaust)	1. Temperature sensor failure 2. Digital programmer circuit failure 3. Loose connector CN5	It is appeared when failure occurred.
F34	Short temperature sensor (exhaust)	1. Temperature sensor failure 2. Digital programmer circuit failure	It is appeared when failure occurred.
F44		1. Shorted power select switch 2. Shorted membrane switch	It is appeared 2 minutes after failure occurred.
F01 (With continuous beep sounds)	Exhaust temperature exceeds 120°C	1. Burning food in the oven due to over cook	It is appeared when exhaust temperature exceeds above 120°C.
F03	Input voltage exceed + 12.5%	1. Increase in power source voltage	It is appeared when the unit is plugged in. Note that it returns normal operation mode by tapping the RESET pad ().
F04	Input voltage is less than — 12.5%	1. Decrease in power source voltage	It is appeared when the unit is plugged in. Note that it returns normal operation mode by tapping the RESET pad ().
F05	Memory failure	1. Digital programmer circuit failure	
No display	1.25/3A fuse blown	1. Switch failure (short switch) 2. Low-Voltage transformer failure	

DISPLAY	CONDITIONS	POSSIBLE CAUSE	TIMING OF FAILURE INDICATION
No display	1.25/3A fuse is OK	1. Thermal cutout failure 2. Low voltage transformer failure 3. Digital programmer circuit failure	
F81	No voltage supply to high voltage trans. (lower/left)	1. Relay failure RY-3 (A) 2. Loose connector CN256, CN257 3. Digital programmer circuit failure	It is appeared when failure occurred.
F84	No voltage supply to high voltage trans. (upper/right)	1. Relay failure RY-9 (C) Loose connector CN262, CN263 2. Digital programmer circuit failure	It is appeared when failure occurred.
F86	Shorted contacts of RY-3	1. Relay failure RY-3 (A) 2. Digital programmer circuit failure	It is appeared when failure occurred.
F89	Shorted contacts of RY-9	1. Relay failure RY-9 (D) 2. Digital programmer circuit failure	It is appeared when failure occurred.

18 EXPLODED VIEW AND PARTS LIST

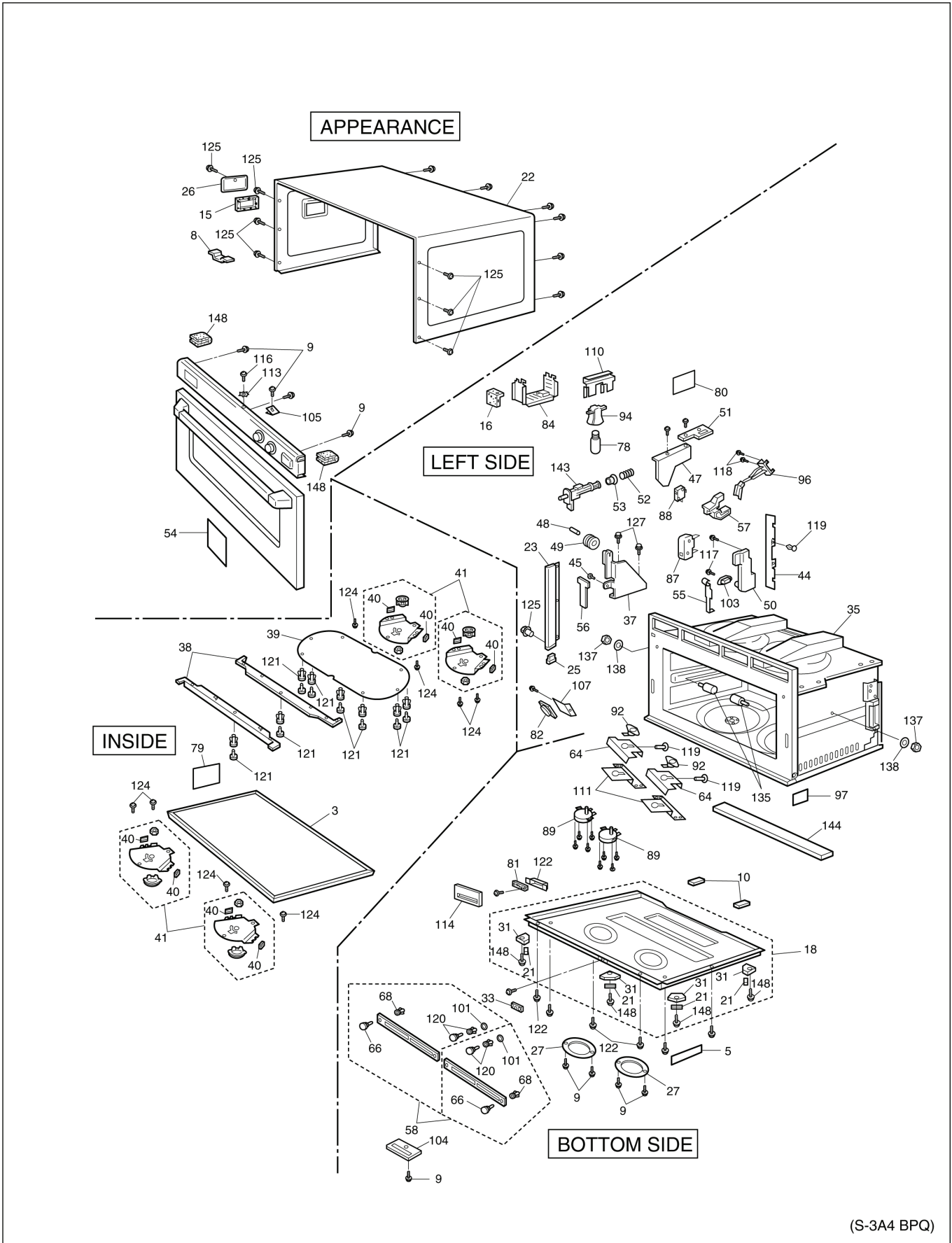

(S-3A4 BPQ)

13.4. When parts must be replaced, always remove the power plug from the outlet, and discharge the high voltage capacitor.

13.5. Confirm after repair

1. After repair or replacement of parts, make sure that the screws of the oven, etc. are neither loose nor missing. Microwave might leak if screws are not properly tightened.
2. Make sure that all electrical connections are tight before inserting the plug into the wall outlet.

13.6. Avoid inserting nails, wire, etc. through holes in unit during operation.

Never insert a wire, nail or any other metal object through the

14 DISASSEMBLY AND PARTS REPLACEMENT PROCEDURE

CAUTION

Serviceman should remove their watches whenever working close to or replacing the magnetron.

14.1. Magnetrons (Upper and Lower)

Upper magnetrons (Right and Left)

1. Discharge electric charge remaining on the high voltage capacitors.
2. Remove the entire rear panel by removing screws as shown in figure.
3. Disconnect all lead wires from magnetron and thermal cutout.
4. Remove the 4 screws holding magnetron.
5. Remove 2 screws holding thermal cutout.
6. Remove the mounting bracket from magnetron and install it on the new magnetron.

Lower magnetrons (Right and Left)

1. Discharge electric charge remaining on the high voltage capacitors.
2. Remove the entire rear panel by removing screws as shown in figure.
3. Disconnect all lead wires from magnetron and thermal cutout.
4. Remove the 4 screws holding magnetron.
5. Remove 2 screws holding thermal cutout.
6. Remove the air guide from magnetron and install it on the new magnetron.

NOTE

To prevent microwave leakage, tighten mounting screws properly making sure there is no gap between the waveguide and the magnetron.

lamp holes on the cavity or any other holes or gaps, because such objects may work as an antenna and cause microwave leakage.

13.7.

CAUTION MICROWAVE RADIATION

Personnel should not be exposed to the microwave energy which may radiate from the magnetron or other microwave generating device if it is improperly used or connected all input and output microwave connections waveguides, flanges, and gasket must be secure. Never operate the device without a microwave energy absorbing load attached. Never look into an open waveguide or antenna while the device is energized.

13.8.

CAUTION

High voltage parts may become uncovered when outer cabinet is removed.

CAUTION

When connecting 2 filament lead wires to the magnetron terminals, be sure to connect the lead wires in the correct position. The lead wire with blue connector should be connected to "FA terminal" and white one should be connected to "F terminal". (See Figure)

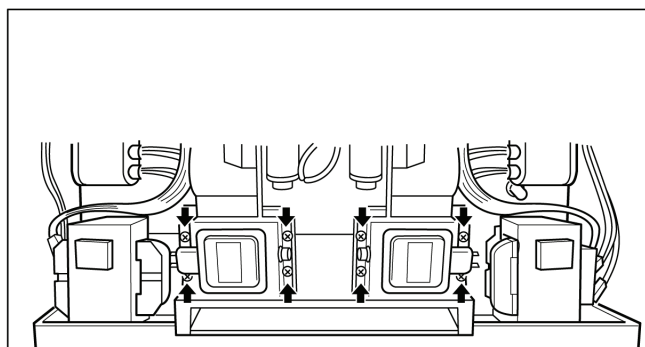

02-051M

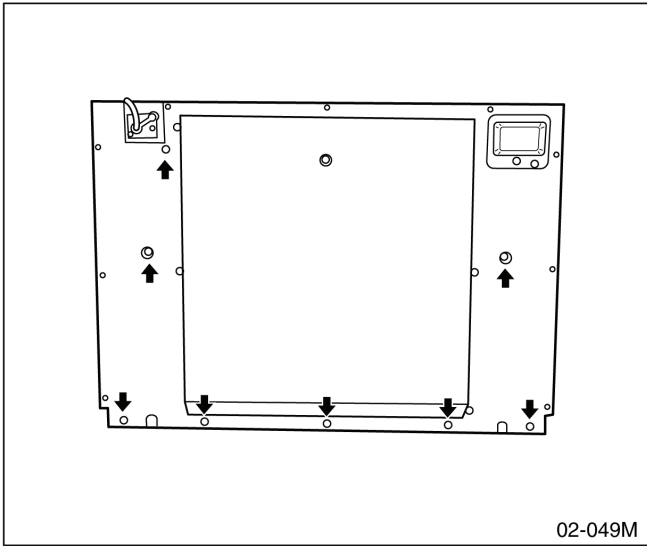

it from main unit then remove connectors.

3. Remove 2 screws holding the D.P.C. board and remove the board by freeing catch hooks.

NOTE

Please use care in handling the power supply P.C.B. and D.P.C. board to avoid damage.

14.3. Low voltage transformer and/or power relays

NOTE

Be sure to ground any static electric charge built up on your body before handling the DPC.

1. Using solder wick or a desoldering tool and 30W soldering iron, carefully remove all solder from the terminal pins of the low voltage transformer and/or power relays.

NOTE

Do not use a soldering iron or desoldering tool of more than 30 watts on DPC contacts.

2. With all the terminal pins cleaned and separated from DPC contacts, remove the defective transformer/power relays and install new transformer/power relays making sure all terminal pins are inserted completely. Resolder all terminal contacts carefully.

14.4. Disassembly of door assembly

1. Detach the door spring ends from right and left door arms.
2. Remove the arm lever right and left by removing 2 screws each on both sides.
3. Remove the sashes right and left by removing 1 screw each on both sides.
4. By holding the door assembly, remove the right and left sides door hinge pins. The door assembly is now free from the oven.
5. Remove 3 screws holding the door A.
6. Remove the door C by using a flat screwdriver as figure.
7. Remove 4 screws holding door handle.
8. Separate door A and door E.
9. Remove the door arms by removing 1 pin each on both sides.

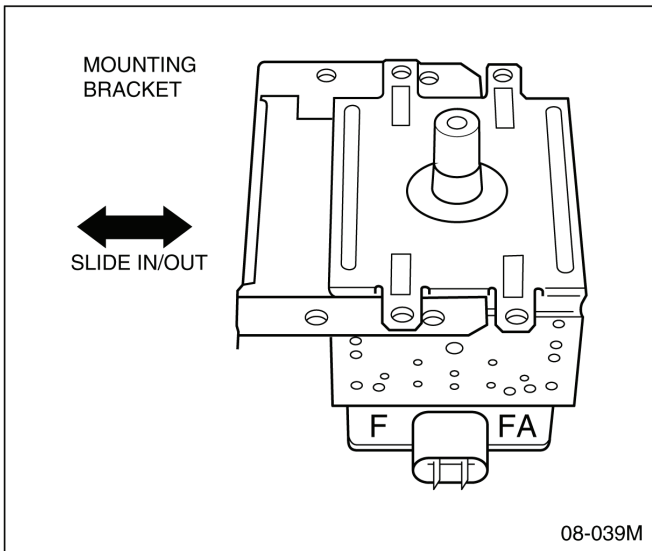
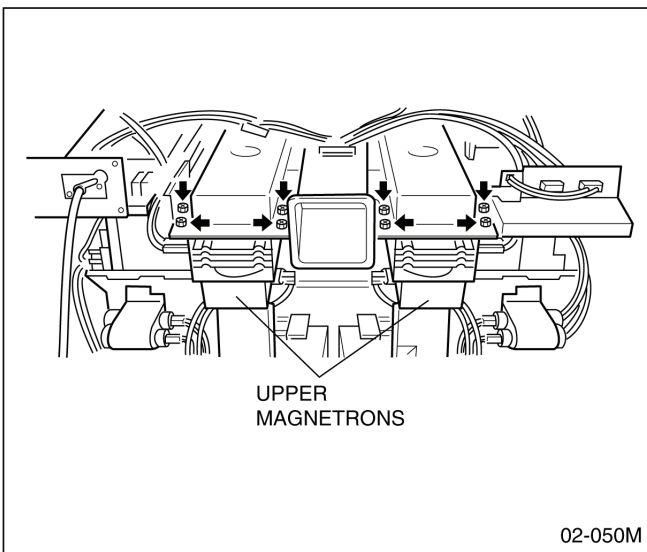

14.2. Digital programmer circuit board

1. Remove grounding screw for membrane switch and D.P.C. ground.
2. Remove 2 screws holding control panel assembly to detach

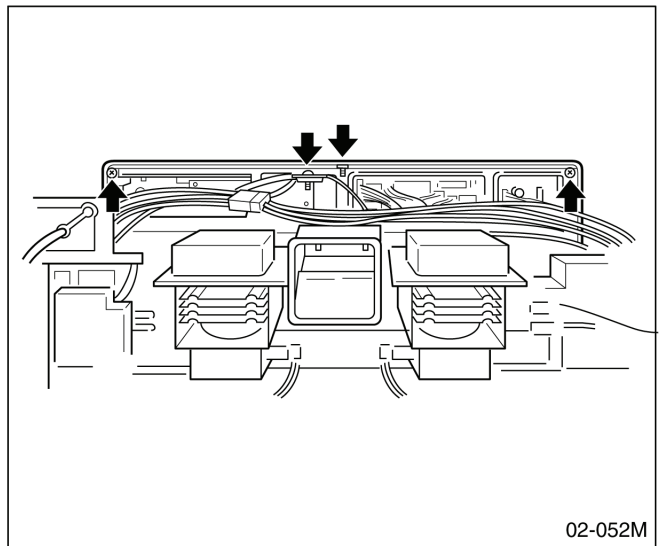

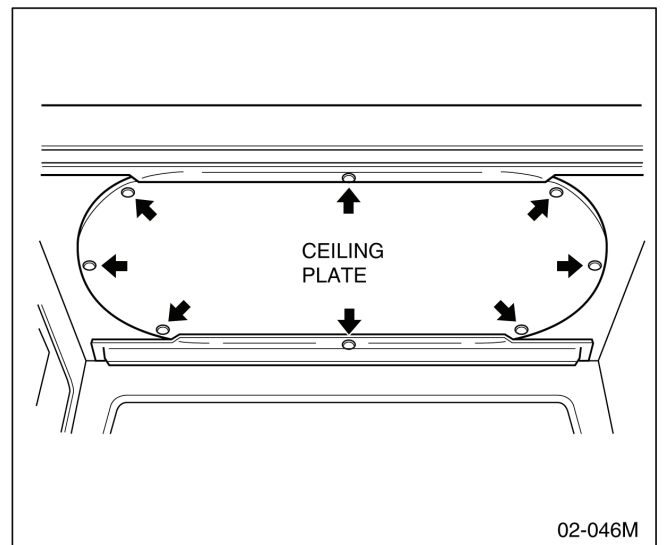
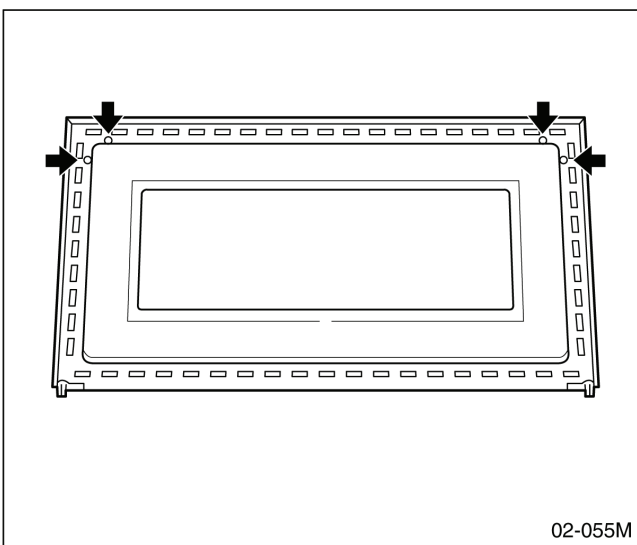
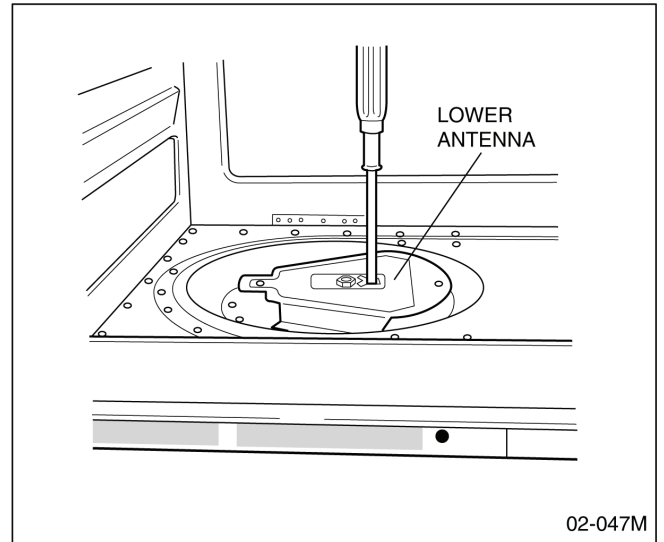
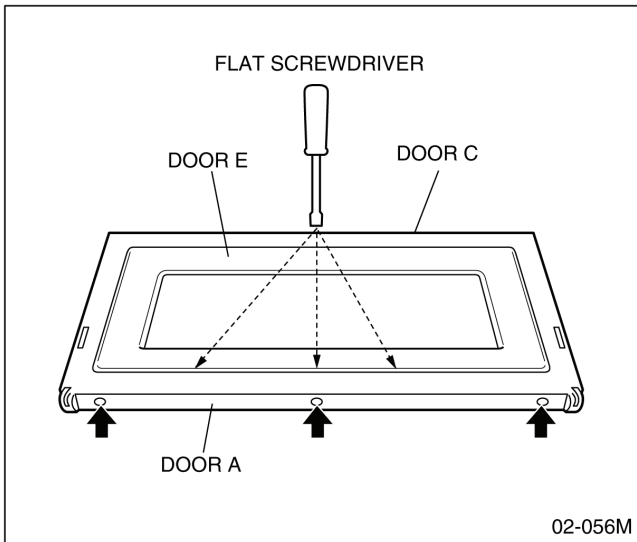

14.5. Upper antenna (Right and Left)

Upper antenna (Right and Left)

1. Remove 8 plastic clips holding ceiling plate and exhaust guides by using flat screwdriver or the like.
2. Remove 2 screws holding upper antenna assy by inserting screwdriver through the opening on the antenna as shown in figure.

14.6. Lower antenna (Right and Left)

Lower antenna (Right and Left)

1. To remove the floor shelf, insert a screwdriver through the openings on the right and left sides of the oven cavity and carefully lift the floor shelf as shown in figure.
2. Remove 2 screws holding lower antenna assy by inserting screwdriver through the opening on the antenna as shown in figure.

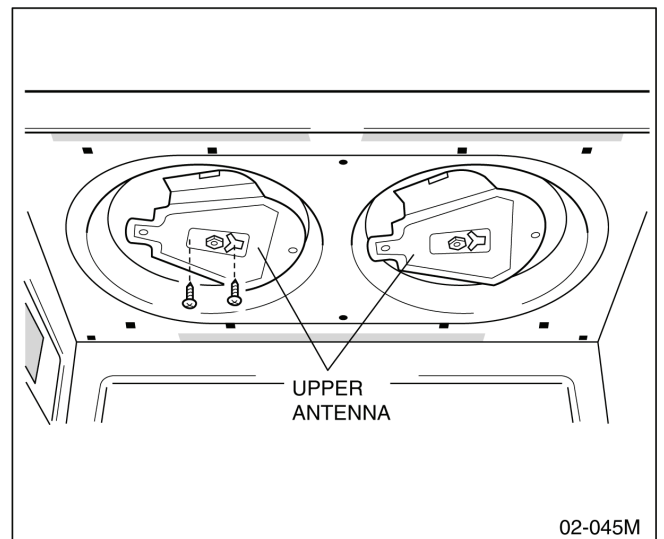

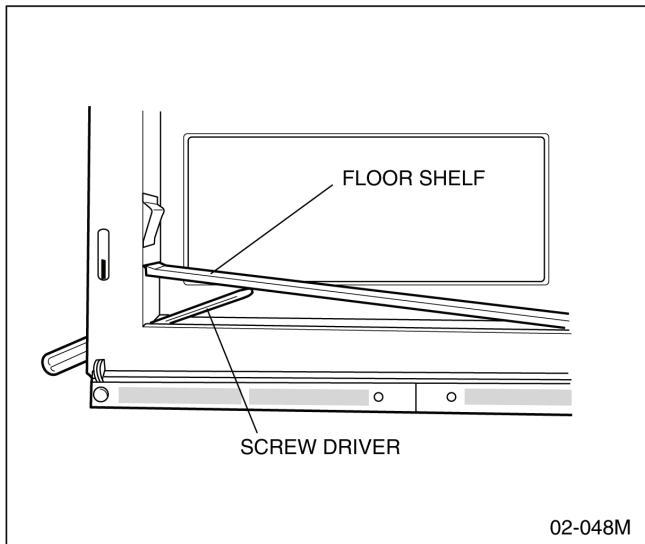

14.7. Replacement of temperature sensor (Thermal protector)

1. Cut 2 lead wires at the top of sensor terminals.
2. Remove 2 screws holding temp sensor and replace with new one.
3. Solder the lead wires securely to the sensor terminals.

14.8. Replacement of antenna motors (upper and lower)

1. The upper antenna motor may be removed by disconnecting the lead wire connectors and removing its 2 mounting screws.

2. To remove the lower antenna motor, carefully place the unit on its left side.
3. Remove the motor cover by removing 2 screws and follow same procedure as for upper antenna.

CAUTION

There are two types of antenna motors. Therefore please replace with correct one as showing below.

Upper Antenna Motor	PART NO.: ANE61446030AP (RATED: 120V)
Lower Antenna Motor	PART NO.: A6144-3280 (RATED: 120V)

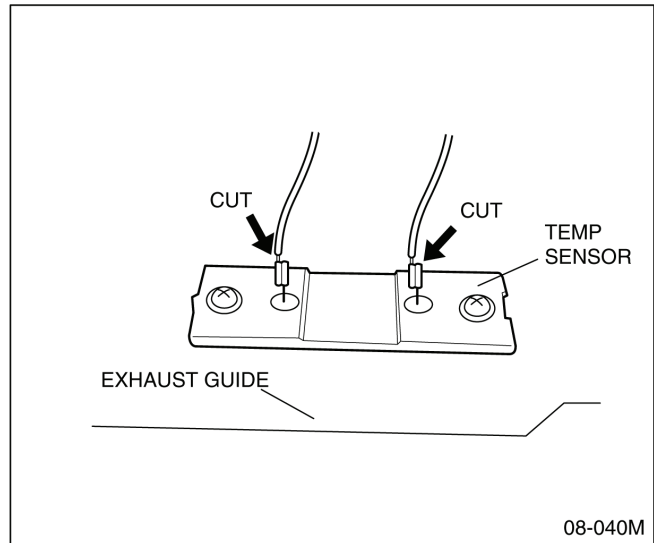

15 COMPONENT TEST PROCEDURE

CAUTION

1. High voltage is present at the high voltage terminal of the high voltage transformer during any cook cycle.
2. It is neither necessary nor advisable to attempt measurement of the high voltage.
3. Before touching any oven components, or wiring, always unplug the oven from its power source and discharge the high voltage capacitor.

15.1. High voltage transformer

1. Remove connections from the transformer terminals and check continuity.
2. Normal (cold) resistance readings should be as follows:
Secondary winding Approx. 40Ω — 100Ω
Filament winding Approx. 0Ω
Primary winding Approx. 0Ω — 3Ω

15.2. High voltage capacitor

1. Check continuity of capacitor with meter on highest OHM scale.
2. A normal capacitor will show continuity for a short time, and then indicate $9M\Omega$ once the capacitor is charged.
3. A shorted capacitor will show continuous continuity.
4. An open capacitor will show constant $9M\Omega$.

5. Resistance between each terminal and chassis should be infinite.

15.3. Magnetron

Continuity checks can only indicate an open filament or a shorted magnetron. To diagnose for an open filament or shorted magnetron.

1. Isolate magnetron from the circuit by disconnecting the leads.
2. A continuity check across magnetron filament terminals should indicate one ohm or less.
3. A continuity check between each filament terminal and magnetron case should read open.

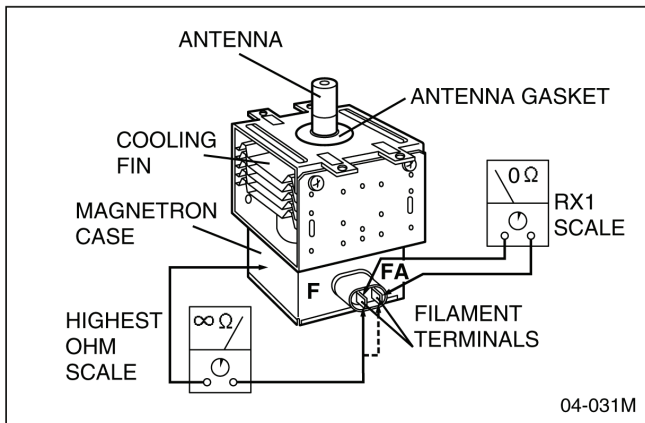
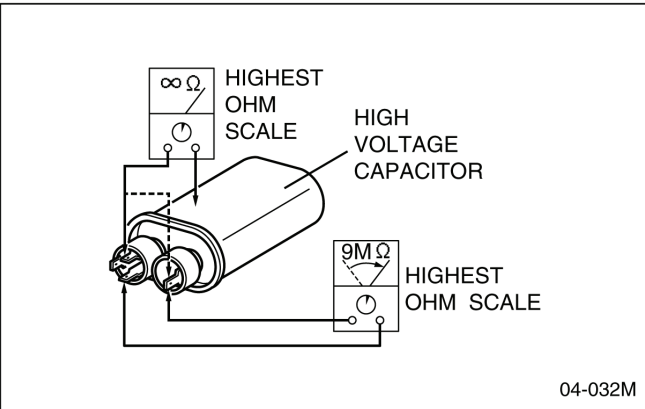
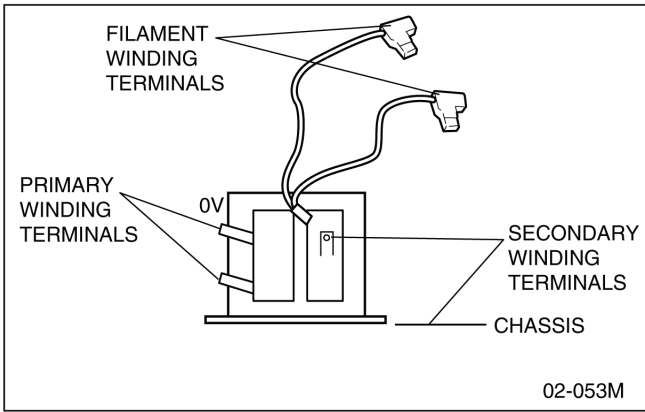

15.4. Diode

1. Isolate the diode from the circuit by disconnecting the leads.
2. With the ohmmeter set on the highest resistance scale, measure the resistance across the diode terminals. Reverse the meter leads and again observe the resistance reading. Meter with 6V, 9V or higher voltage batteries should be used to check the front-to-back resistance of the diode, otherwise an infinite resistance may be read in both directions. A normal diode's resistance will be infinite in one direction and several hundred k in the other direction.

15.5. Membrane key board (Membrane switch assembly)

Check continuity between switch terminals, by tapping an

appropriate pad on the key board. The contacts assignment of the respective pads on the key board is as shown in digital programmer circuit.

15.6. Protector diode

1. Isolate the protector diode assembly from the circuit by disconnecting its leads.
2. With the ohmmeter set on the highest resistance scale, measure the resistance across the protector diode terminals. Reverse the meter leads and again observe the resistance reading. A normal protector diode's resistance will be infinite in both directions. It is faulty if it shows continuity in one or both directions.

15.7. Temp sensor (Thermal protector)

A temp sensor is mounted on exhaust guide. Its purpose is to automatically shut off the oven in case the cavity overheats for any reason.

The thermal protector will operate at 257°F(125°C).

The device is connected to the DPC on touch control modes.

When the thermal protector exceeds its temperature it will turn off the power to oven cavity and display will go to reset mode.

The cooking program can be rest after cool-down.

THERMISTOR RESISTANCE VALUE

30K-120K at 10°C-30°C (50°F — 86°F)

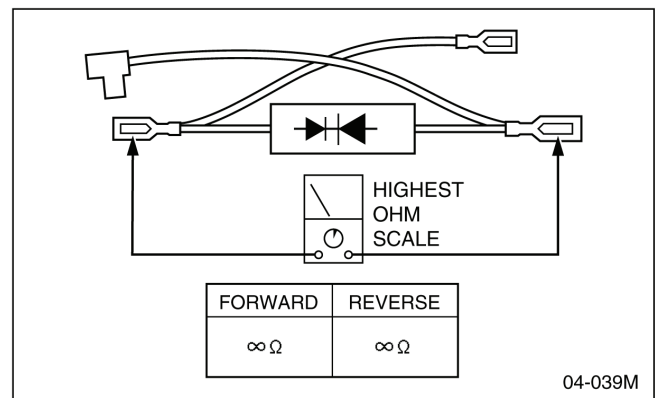
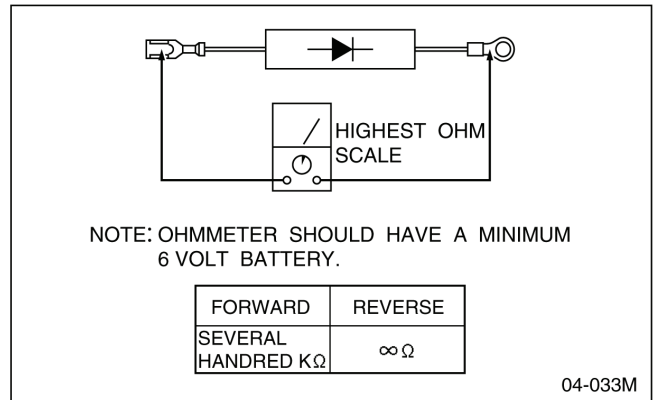

16 MEASUREMENTS AND ADJUSTMENTS

16.1. Adjustment of the safety switch B (Right and Left side)

1. Switch operation

When the door is slightly opened, the safety switch B opens the main circuit. The movement of the door from the closed position to the operation position (shown as liter) of the switch when it opens the main circuit, must maintain within following tolerances.

SAFETY SWITCH B (liter) = 3 mm — 5mm

(When safety switch B opens the main circuit)

NOTE

Make sure that safety switch A turns off prior to the safety switch B when the door is gradually opened.

2. How to adjust safety switch B

Loosen 2 screws which secure the safety switch B bracket to the bracket of the oven assembly and then adjust the safety switch B bracket by moving it to either direction as shown in figure.

16.2. Adjustment of the Short Switch (Right and Left side)

1. When the door is slightly opened, the Short Switch opens the main circuit and closes the contacts for short circuit. The movement of door from its closed position to open position at which the Short Switch contacts open the main circuit (shown as liter) must maintain within 8mm — 11mm and at which the switch contacts close the short circuit should be 20mm — 35mm.

2. How to adjust

Loosen the 2 screws holding the short switch to the short switch bracket, and then adjust the safety switch A by moving it to either direction as shown in figure.

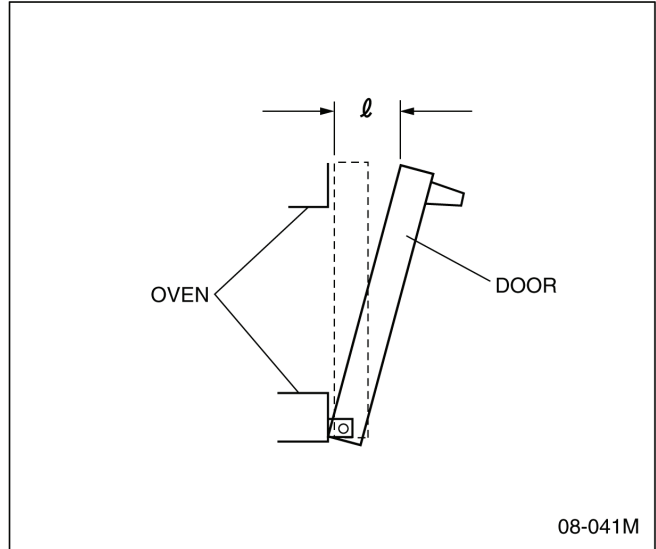
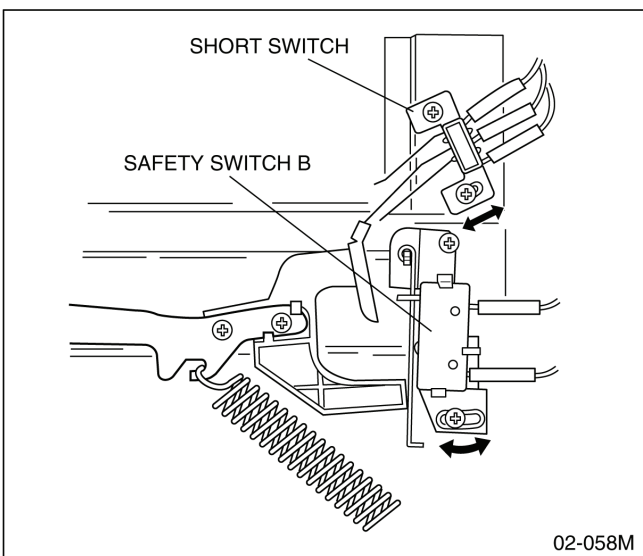

16.3. Adjustment of the safety switch A (Door switch) (Right and Left side)

1. Switch operation

When the door is slightly opened, the contacts of safety switch A opened to give digital programmer circuit the information that the door is opened. The allowable movement of the door from the closed position to the operating position (shown as liter) of the switch when it opens the circuit, is specified as follows;

SAFETY SWITCH A (liter) = 1mm — 3mm

(When safety switch A opens the circuit)

NOTE

Make sure that safety switch A turn off prior to the safety switch B when the door is gradually opened.

2. How to adjust safety switch A

Loosen 2 screws which secure the safety switch A bracket to the bracket of the oven assembly and then adjust the safety switch A bracket by moving it to either direction as shown in figure.

16.4. Measurement of microwave output

The output power of the magnetron can be determined by performing IEC standard test procedures. However, it is possible to test the magnetron by following procedure outlined below. Necessary equipment:

- 1 litre beaker
- Glass thermometer
- Wrist watch or stopwatch

NOTE

Check the line voltage under load to ensure it meets specifications. Low voltage condition will cause a reduction in magnetron output. Temperature readings and heating time, should be as accurate as possible.

Output power performance test procedure.

1. Fill the beaker with exactly one litre of tap water. Stir the water using the thermometer and note the temperature. (Record as T1)
2. Place the beaker in the center of cook plate. Set the oven for High power and heat for exactly one minute.
3. After completion of the heating cycle, stir the water again with the thermometer and note the temperature. (Record as T2)

The normal temperature rise ($T2 - T1$) at High power position for each models is as shown in following table.

Model	Temperature Rise (1 liter — 1 Min.)
NE-3280 NE-3240	Min. 27.4°C
NE-2180 NE-2140	Min. 18°C

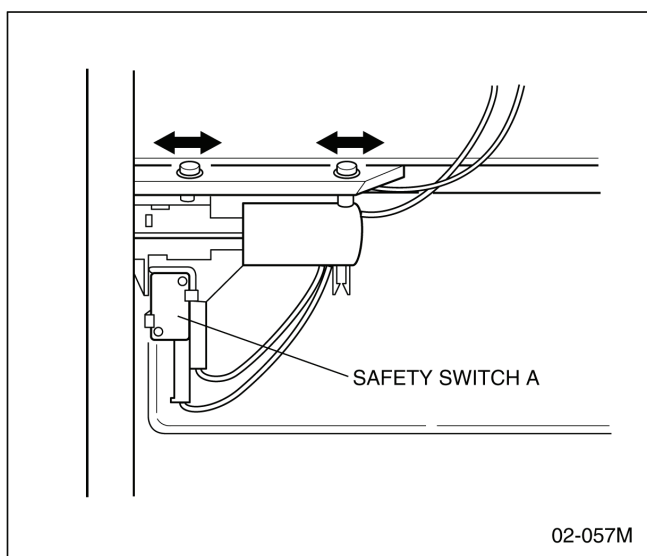
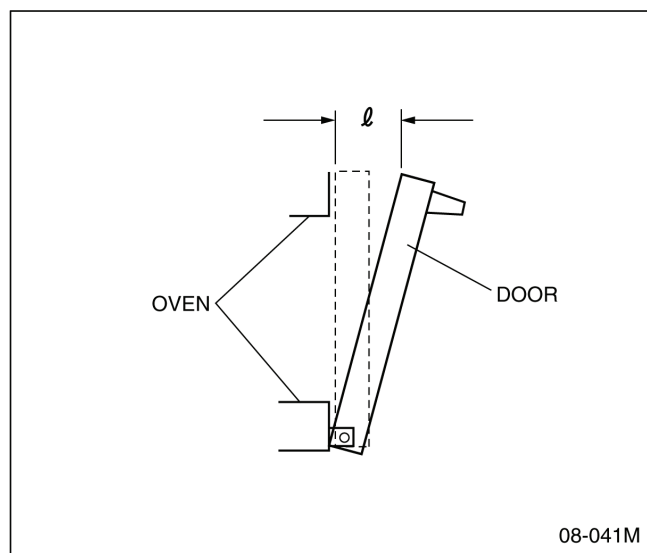

17 TROUBLESHOOTING GUIDE

CAUTION

1. Check grounding before checking for trouble.
2. Be careful of high voltage circuit.
3. Discharge high voltage capacitor.
4. When checking the continuity of the switches or the high voltage transformer, disconnect one lead wire from these parts and then check continuity with the AC plug removed. To do otherwise may result in a false reading or damage to your meter.
When disconnecting a plastic connector from a terminal, you must hold the plastic connector instead of the lead wire and then disconnect it, otherwise lead wire may be open or the connector cannot be removed.
5. Be sure to ground any static electric charge built up in your body, before handling the D.P.C.
6. A 230-240V/400V AC is present at the shaded area () of the power supply circuit board (Terminals of power relays and primary circuit of low voltage transformer). When troubleshooting, be cautious of possible electrical shock hazard.

First of all operate the microwave oven following the correct operating procedures described on pages 3 of this service manual in order to find the exact cause of any trouble.

NOTE

If the unit shows faulty symptom as shown below, check the parts listed in possible cause column depending on failure indication e.g. F81, F82 in the display.

[TROUBLE] Oven does not operate at all or oven does not start cooking. NE-3280, NE-3240

DISPLAY	CONDITIONS	POSSIBLE CAUSE	TIMING OF FAILURE INDICATION
F33	Open temperature sensor (exhaust)	1. Temperature sensor failure 2. Digital programmer circuit failure 3. Loose connector CN5	It is appeared when failure occurred.

DISPLAY	CONDITIONS	POSSIBLE CAUSE	TIMING OF FAILURE INDICATION
F34	Short temperature sensor (exhaust)	1. Temperature sensor failure 2. Digital programmer circuit failure	It is appeared when failure occurred.
F44		1. Shorted power select switch 2. Shorted membrane switch	It is appeared 2 minutes after failure occurred.
F01 (With continuous beep sounds)	Exhaust temperature exceeds 120°C	1. Burning food in the oven due to over cook	It is appeared when exhaust temperature exceeds above 120°C.
F03	Input voltage exceed + 12.5%	1. Increase in power source voltage	It is appeared when the unit is plugged in. Note that it returns normal operation mode by tapping the RESET pad ().
F04	Input voltage is less than — 12.5%	1. Decrease in power source voltage	It is appeared when the unit is plugged in. Note that it returns normal operation mode by tapping the RESET pad ().
F05	Memory failure	1. Digital programmer circuit failure	
No display	1.25/3A fuse blown	1. Switch failure (short switch) 2. Low-Voltage transformer failure	
No display	1.25/3A fuse is OK	1. Thermal cutout failure 2. Low voltage transformer failure 3. Digital programmer circuit failure	
F81	No voltage supply to high voltage trans. (lower/left)	1. Relay failure RY-3 (A) 2. Loose connector CN256, CN257 3. Digital programmer circuit failure	It is appeared when failure occurred.
F82	No voltage supply to high voltage trans. (lower/right)	1. Relay failure RY-5 (B) 2. Loose connector CN258, CN259 3. Digital programmer circuit failure	It is appeared when failure occurred.
F83	No voltage supply to high voltage trans. (upper/left)	1. Relay failure RY-7 (C) Loose connector CN260, CN261 2. Digital programmer circuit failure	It is appeared when failure occurred.
F84	No voltage supply to high voltage trans. (upper/right)	1. Relay failure RY-9 (C) Loose connector CN262, CN263 2. Digital programmer circuit failure	It is appeared when failure occurred.
F86	Shorted contacts of RY-3	1. Replay failure RY-3 (A) 2. Digital programmer circuit failure	It is appeared when failure occurred.
F87	Shorted contacts of RY-5	1. Replay failure RY-5 (B) 2. Digital programmer circuit failure	It is appeared when failure occurred.
F88	Shorted contacts of RY-7	1. Replay failure RY-7 (C) 2. Digital programmer circuit failure	It is appeared when failure occurred.
F89	Shorted contacts of RY-9	1. Replay failure RY-9 (D) 2. Digital programmer circuit failure	It is appeared when failure occurred.

[TROUBLE]Oven does not operate at all or oven does not start cooking. NE-2180, NE-2140

DISPLAY	CONDITIONS	POSSIBLE CAUSE	TIMING OF FAILURE INDICATION
F33	Open temperature sensor (exhaust)	1. Temperature sensor failure 2. Digital programmer circuit failure 3. Loose connector CN5	It is appeared when failure occurred.
F34	Short temperature sensor (exhaust)	1. Temperature sensor failure 2. Digital programmer circuit failure	It is appeared when failure occurred.
F44		1. Shorted power select switch 2. Shorted membrane switch	It is appeared 2 minutes after failure occurred.
F01 (With continuous beep sounds)	Exhaust temperature exceeds 120°C	1. Burning food in the oven due to over cook	It is appeared when exhaust temperature exceeds above 120°C.
F03	Input voltage exceed + 12.5%	1. Increase in power source voltage	It is appeared when the unit is plugged in. Note that it returns normal operation mode by tapping the RESET pad ().
F04	Input voltage is less than — 12.5%	1. Decrease in power source voltage	It is appeared when the unit is plugged in. Note that it returns normal operation mode by tapping the RESET pad ().
F05	Memory failure	1. Digital programmer circuit failure	
No display	1.25/3A fuse blown	1. Switch failure (short switch) 2. Low-Voltage transformer failure	

DISPLAY	CONDITIONS	POSSIBLE CAUSE	TIMING OF FAILURE INDICATION
No display	1.25/3A fuse is OK	1. Thermal cutout failure 2. Low voltage transformer failure 3. Digital programmer circuit failure	
F81	No voltage supply to high voltage trans. (lower/left)	1. Relay failure RY-3 (A) 2. Loose connector CN256, CN257 3. Digital programmer circuit failure	It is appeared when failure occurred.
F84	No voltage supply to high voltage trans. (upper/right)	1. Relay failure RY-9 (C) Loose connector CN262, CN263 2. Digital programmer circuit failure	It is appeared when failure occurred.
F86	Shorted contacts of RY-3	1. Relay failure RY-3 (A) 2. Digital programmer circuit failure	It is appeared when failure occurred.
F89	Shorted contacts of RY-9	1. Relay failure RY-9 (D) 2. Digital programmer circuit failure	It is appeared when failure occurred.

18 EXPLODED VIEW AND PARTS LIST

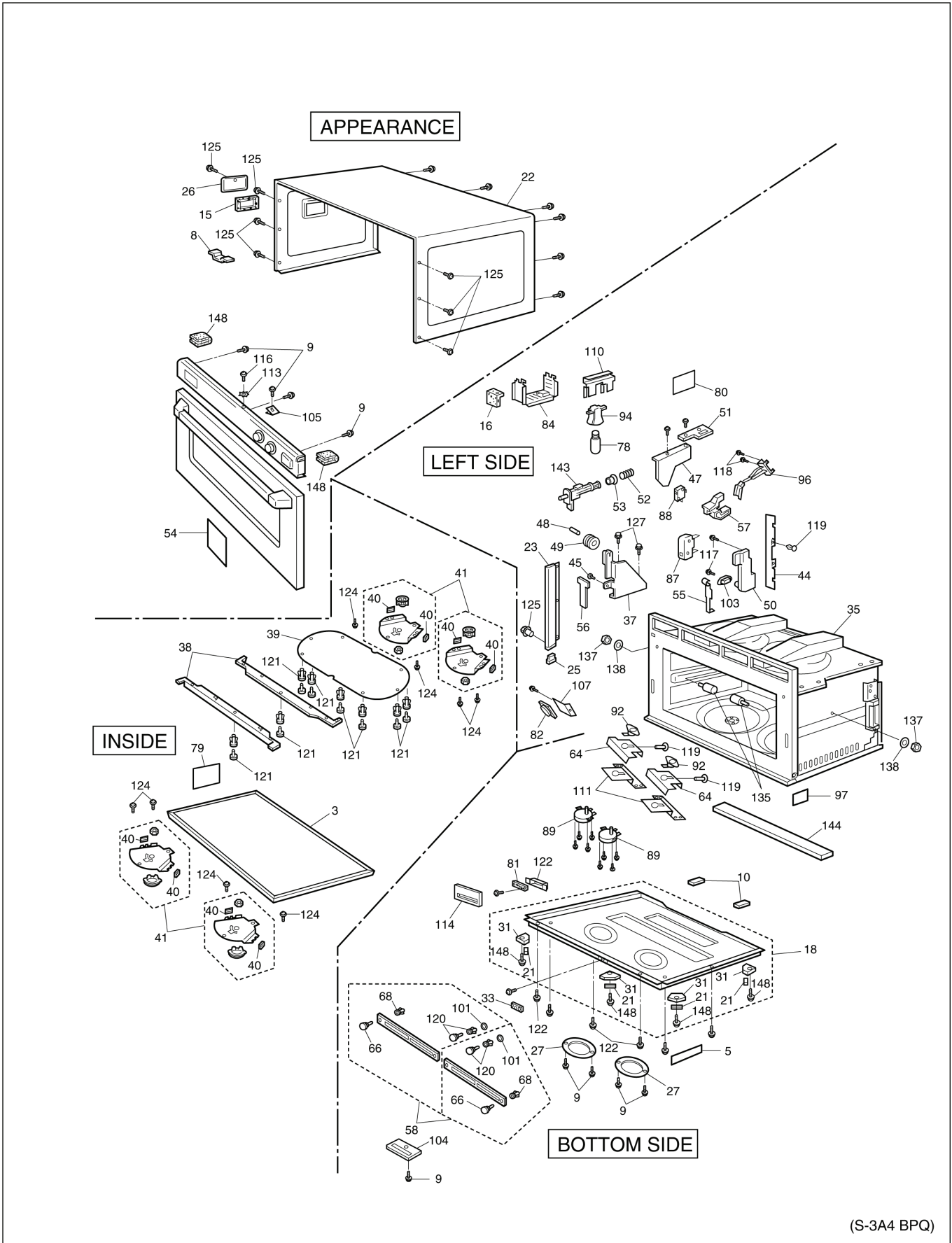

(S-3A4 BPQ)

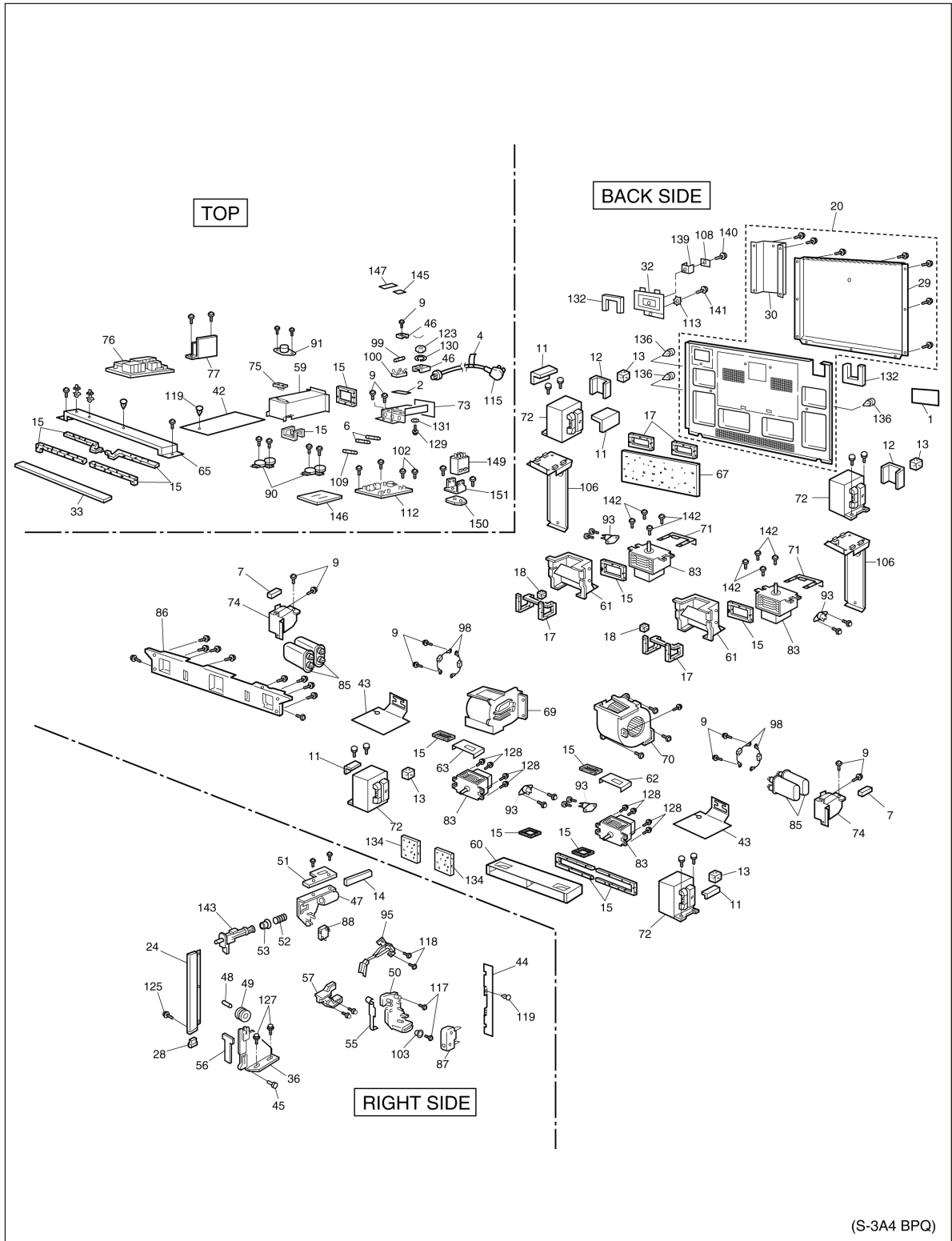

19 PARTS LIST

NOTE

When ordering replacement part(s), please use part number(s) shown in this parts list.

Do not use description of the part.

Important safety notice:

Components identified by  mark have special characteristics important for safety.

When replacing any of these components, use only manufacturer's specified parts.

Ref. No.	Part No.	Part Name & Description	Pcs/Set	Remarks
1	A00064080BP	CAUTION LABEL	1	FOR BPQ

Ref. No.	Part No.	Part Name & Description	Pcs/Set	Remarks
1	ANE00062Q0EP	CAUTION LABEL	1	FOR EUG
2	A00333030GP	FUSE LABEL	1	NE-3240
2	A00333A60BP	FUSE LABEL	1	NE-2180
3	ANE0033P10GN	FUSE LABEL	1	NE-2140
3	A010T3030GP	SHELF	1	
4	A02393A80BP	CORD LABEL	1	NE-3280,NE-2180
5	A05243A40BP	NAME LABEL	1	NE-3280
5	A05243A50BP	NAME LABEL	1	NE-2180
5	A05243A60EU	NAME LABEL	1	NE-3240
5	A05243A70EU	NAME LABEL	1	NE-2140
6	A67593030GP	FUSE	2	△ NE-3240 (10A)
6	A67593560GP	FUSE	2	△ NE-2140 (7A)
7	ANE0911000DC	CUSHION RUBBER B	1	NE-3280
7	ANE0911000DC	CUSHION RUBBER B	1	NE-3280
8	ANE0911000DF	CUSHION RUBBER B	1	
9	XYD4+EE12F	SCREW	19	NE-3240,NE-2140,2180 (4X12) (FOR TERMINAL PLATE ANTENNA,MOTOR COVER, SWITCH HOLDER,DIODE,CAPACITOR BRACKET, ESCUTCHEON BASE,DPC EARTH)
9	XYD4+EE12F	SCREW	18	NE-3280 (FOR TERMINAL PLATE ANTENNA, MOTOR COVER , SWITCH HOLDER,DIODE, CAPACITOR BRACKET,ESCUTCHEON BASE,DPC EARTH)
9	XYD4+EE12F	SCREW	19	NE-3240,NE-2140,2180 (4X12) (FOR TERMINAL PLATE ANTENNA,MOTOR COVER, SWITCH HOLDER,DIODE,CAPACITOR BRACKET, ESCUTCHEON BASE,DPC EARTH)
9	XYD4+EE12F	SCREW	19	NE-3240,NE-2140,2180 (4X12) (FOR TERMINAL PLATE ANTENNA,MOTOR COVER, SWITCH HOLDER,DIODE,CAPACITOR BRACKET, ESCUTCHEON BASE,DPC EARTH)
9	XYD4+EE12F	SCREW	19	NE-3240,NE-2140,2180 (4X12) (FOR TERMINAL PLATE ANTENNA,MOTOR COVER, SWITCH HOLDER,DIODE,CAPACITOR BRACKET, ESCUTCHEON BASE,DPC EARTH)
9	XYD4+EE12F	SCREW	19	NE-3240,NE-2140,2180 (4X12) (FOR TERMINAL PLATE ANTENNA,MOTOR COVER, SWITCH HOLDER,DIODE,CAPACITOR BRACKET, ESCUTCHEON BASE,DPC EARTH)
9	XYD4+EE12F	SCREW	19	NE-3240,NE-2140,2180 (4X12) (FOR TERMINAL PLATE ANTENNA,MOTOR COVER, SWITCH HOLDER,DIODE,CAPACITOR BRACKET, ESCUTCHEON BASE,DPC EARTH)
9	XYD4+EE12F	SCREW	19	NE-3240,NE-2140,2180 (4X12) (FOR TERMINAL PLATE ANTENNA,MOTOR COVER, SWITCH HOLDER,DIODE,CAPACITOR BRACKET, ESCUTCHEON BASE,DPC EARTH)
9	XYD4+EE12F	SCREW	19	NE-3240,NE-2140,2180 (4X12) (FOR TERMINAL PLATE ANTENNA,MOTOR COVER, SWITCH HOLDER,DIODE,CAPACITOR BRACKET, ESCUTCHEON BASE,DPC EARTH)
9	XYD4+EE12F	SCREW	19	NE-3240,NE-2140,2180 (4X12) (FOR TERMINAL PLATE ANTENNA,MOTOR COVER, SWITCH HOLDER,DIODE,CAPACITOR BRACKET, ESCUTCHEON BASE,DPC EARTH)
9	XYD4+EE12F	SCREW	19	NE-3240,NE-2140,2180 (4X12) (FOR TERMINAL PLATE ANTENNA,MOTOR COVER, SWITCH HOLDER,DIODE,CAPACITOR BRACKET, ESCUTCHEON BASE,DPC EARTH)
9	XYD4+EE12F	SCREW	19	NE-3240,NE-2140,2180 (4X12) (FOR TERMINAL PLATE ANTENNA,MOTOR COVER, SWITCH HOLDER,DIODE,CAPACITOR BRACKET, ESCUTCHEON BASE,DPC EARTH)
9	XYD4+EE12F	SCREW	19	NE-3240,NE-2140,2180 (4X12) (FOR TERMINAL PLATE ANTENNA,MOTOR COVER, SWITCH HOLDER,DIODE,CAPACITOR BRACKET, ESCUTCHEON BASE,DPC EARTH)
10	ANE0911000EG	CUSHION RUBBER B	2	
11	ANE0911000EH	CUSHION RUBBER B	2	NE-2180,NE-2140
11	ANE0911000EH	CUSHION RUBBER B	4	NE-3280,NE-3240
11	ANE0911000EH	CUSHION RUBBER B	2	NE-2180,NE-2140
11	ANE0911000EH	CUSHION RUBBER B	2	NE-2180,NE-2140
12	ANE0911000MG	CUSHION RUBBER B	2	NE-3280,NE-3240
12	ANE0911000MG	CUSHION RUBBER B	2	NE-3280,NE-3240
13	ANE0917000EB	CUSHION RUBBER B	2	
13	ANE0917000EB	CUSHION RUBBER B	2	
13	ANE0917000EB	CUSHION RUBBER B	2	
13	ANE0917000EB	CUSHION RUBBER B	2	
14	ANE0921000CG	CUSHION RUBBER C	1	
15	ANE0922000AR	CUSHION RUBBER C	14	
15	ANE0922000AR	CUSHION RUBBER C	14	
15	ANE0922000AR	CUSHION RUBBER C	14	
15	ANE0922000AR	CUSHION RUBBER C	14	
15	ANE0922000AR	CUSHION RUBBER C	14	
15	ANE0922000AR	CUSHION RUBBER C	14	
15	ANE0922000AR	CUSHION RUBBER C	14	
15	ANE0922000AR	CUSHION RUBBER C	14	
15	ANE0922000AR	CUSHION RUBBER C	14	
15	ANE0922000AR	CUSHION RUBBER C	14	
15	ANE0922000AR	CUSHION RUBBER C	14	
15	ANE0922000AR	CUSHION RUBBER C	14	

Ref. No.	Part No.	Part Name & Description	Pcs/Set	Remarks
15	ANE0922000AR	CUSHION RUBBER C	14	
15	ANE0922000AR	CUSHION RUBBER C	14	
16	ANE0922000JE	CUSHION RUBBER C	1	
17	ANE0923000AV	CUSHION RUBBER C	2	
17	ANE0923000AV	CUSHION RUBBER C	2	
17	ANE0923000AV	CUSHION RUBBER C	2	
18	ANE0924000AB	CUSHION RUBBER C	2	
18	ANE0924000AB	CUSHION RUBBER C	2	
18	ANE0924000AB	CUSHION RUBBER C	2	
19	A100A3560BP	BASE	1	(NOTE)
20	A100Q3560GP	BACK PANEL	1	
21	A1008-3280	RUBBER FOOT	4	
21	A1008-3280	RUBBER FOOT	4	
21	A1008-3280	RUBBER FOOT	4	
21	A1008-3280	RUBBER FOOT	4	
22	A10093030GP	CABINET BODY(U)	1	
23	A10133030GP	LEFT SIDE SASH	1	
24	A10143030GP	RIGHT SIDE SASH	1	
25	A10203030GP	SASH RUBBER B	1	LEFT
26	A10263030GP	LAMP COVER	1	
27	A10283030GP	ANTENNA MOTOR COVER	2	
27	A10283030GP	ANTENNA MOTOR COVER	2	
28	A10503030GP	SASH RUBBER A	1	RIGHT
29	A10583560GP	BACK PANEL COVER A	1	
30	A10593560GP	BACK PANEL COVER B	1	
31	A1007-3280	FOOT A	4	
31	A1007-3280	FOOT A	4	
31	A1007-3280	FOOT A	4	
31	A1007-3280	FOOT A	4	
32	A101H3170GP	BACK PANEL COVER C	1	
32	A101H3170GP	BACK PANEL COVER C	1	
32	A101H3170GP	BACK PANEL COVER C	1	
32	A101H3170GP	BACK PANEL COVER C	1	
33	A11743060GP	SPACER	1	
33	A11743060GP	SPACER	1	
34	A16163030GP	PANEL B(U)	1	NE-3280,NE-3240,NE-2140
34	A16163060GP	PANEL B(U)	1	NE-2180
35	A200A3560GP	OVEN	1	
36	A200P3030GP	ROLLER BRACKET A	1	RIGHT
37	A200Q3030GP	ROLLER BRACKET B	1	LEFT
38	A20103030GP	CEILING PLATE B	2	
39	A20113030GP	CEILING PLATE	1	
40	A20193030GP	ANTENNA STOPPER	8	
40	A20193030GP	ANTENNA STOPPER	8	
40	A20193030GP	ANTENNA STOPPER	8	
40	A20193030GP	ANTENNA STOPPER	8	
40	A20193030GP	ANTENNA STOPPER	8	
40	A20193030GP	ANTENNA STOPPER	8	
40	A20193030GP	ANTENNA STOPPER	8	
40	A20193030GP	ANTENNA STOPPER	8	
41	A202R3560GP	ANTENNA (U)	4	
41	A202R3560GP	ANTENNA (U)	4	
42	A22173030GP	BARRIER SHEET A	1	
43	A22183030GP	BARRIER SHEET B	2	NE-3280,NE-3240
43	A22183030GP	BARRIER SHEET B	2	NE-3280,NE-3240
44	A22193030GP	BARRIER SHEET C	1	NE-2180,NE-2140
44	A22193030GP	BARRIER SHEET C	2	NE-3280,NE-3240
45	ANE3008P00RN	HINGE PIN	2	
45	ANE3008P00RN	HINGE PIN	2	
46	XWNAE53GV	SPACER	1	(FOR CORD EARTH)
46	XWNAE53GV	SPACER	1	(FOR CORD EARTH)
47	A30203030GP	DOOR HOOK A	2	
47	A30203030GP	DOOR HOOK A	2	
48	ANE3033-560	DOOR ROLLER PIN	2	
48	ANE3033-560	DOOR ROLLER PIN	2	
49	ANE3034-560	DOOR GUIDE ROLLER	2	
49	ANE3034-560	DOOR GUIDE ROLLER	2	
50	A31123050GP	DOOR HOOK B	2	NE-3280,NE-2180
50	A31123030GP	DOOR HOOK B	2	NE-3240,NE-2140
51	A31363030GP	HOOK SPACER A	2	
51	A31363030GP	HOOK SPACER A	2	
52	ANE3155-610	SPRING	2	
52	ANE3155-610	SPRING	2	
53	ANE3157-610	PACKING RUBBER	2	

Ref. No.	Part No.	Part Name & Description	Pcs/Set	Remarks
53	ANE3157-610	PACKING RUBBER	2	
54	A31863A40BP	DOOR PANEL	1	NE-3280
54	A31863A50EU	DOOR PANEL	1	NE-3240
54	A31863A60BP	DOOR PANEL	1	NE-2180
54	A31863A70EU	DOOR PANEL	1	NE-2140
55	A32493030GP	DOOR SWITCH LEVER	2	
55	A32493030GP	DOOR SWITCH LEVER	2	
56	A32523030GP	DOOR ARM SPACER	2	
56	A32523030GP	DOOR ARM SPACER	2	
57	A33373030GP	DOOR ARM LEVER	2	
57	A33373030GP	DOOR ARM LEVER	2	
58	A400B3040AP	AIR FILTER FLAME(U)	2	
59	A400C3040AP	EXHAUST GUIDE B	1	
60	A402N3030GP	EXHAUST GUIDE A	1	
61	A40253030GP	AIR GUIDE A	2	
61	A40253030GP	AIR GUIDE A	2	
62	A40263030GP	AIR GUIDE B	1	
63	A40313030GP	AIR GUIDE C	1	
64	A40423040AP	AIR GUIDE F	2	
64	A40423040AP	AIR GUIDE F	2	
65	A40473560GP	AIR GUIDE E	1	
66	A40923030GP	FILTER HANDLE	2	
66	A40923030GP	FILTER HANDLE	2	
67	A40963030GP	INSULATION SHEET	1	
68	ANE42408U0AP	FILTER HANDLE B	2	
68	ANE42408U0AP	FILTER HANDLE B	2	
69	A490W3050GP	FAN MOTOR A	1	NE-2180,NE-2140
69	A490W3030GP	FAN MOTOR A	1	NE-3280,NE-3240
70	A490Y3050GP	FAN MOTOR B	1	NE-2180,NE-2140
70	A490Y3030GP	FAN MOTOR B	1	NE-3280,NE-3240
71	ANE50328U0AP	MAGNETRON BRACKET	2	
71	ANE50328U0AP	MAGNETRON BRACKET	2	
72	A622A3A50EU	H.V.TRANSFORMER	2	△ NE-3240
72	A622A3A50BP	H.V.TRANSFORMER	4	△ NE-3280
72	A622A3A60BP	H.V.TRANSFORMER	2	△ NE-2180
72	A622A3A70EU	H.V.TRANSFORMER	2	△ NE-2140
73	A600E3030GP	TERMINAL PLATE	1	
73	A600E3030BP	TERMINAL PLATE	1	
74	A600S3030GP	CAPACITOR BRACKET	2	NE-2180,NE-2140
74	A600S3A40BP	CAPACITOR BRACKET	2	NE-3280,NE-3240
75	A601L4000AP	TEMP SENSOR	1	
76	A603M3560BP	P.C. BOARD B(U)	1	NE-3280
76	A603M3560GP	P.C. BOARD B(U)	1	NE-3240
76	A603M3580GP	P.C. BOARD B(U)	1	NE-2180
76	A603M3A70EU	P.C. BOARD B(U)	1	NE-2140
77	A603Y3560GP	L.V.TRANSFORMER(U)	1	△
78	ANE6030Q50GN	INCANDESCENT LAMP	1	240V/25W
79	A60403030GP	OVEN LAMP SHEET	1	
80	A60403040AP	OVEN LAMP SHEET	1	
81	A605Q3030GP	PUSH SWITCH	1	
82	A605S3030GP	PC BOARD H(U)	1	
83	2M210-M1GL	MAGNETRON	4	NE-2180,NE-2140
83	2M244-M1GL	MAGNETRON	4	△ NE-3280,NE-3240
83	2M244-M1GL	MAGNETRON	4	△ NE-3280,NE-3240
83	2M244-M1GL	MAGNETRON	4	△ NE-3280,NE-3240
84	A60733030GP	OVEN LAMP COVER	1	
85	A63903310GP	H.V.CAPACITOR	4	△ NE-2180,NE-2140(0.82MF, AC2300V)
85	A63903330GP	H.V.CAPACITOR	4	△ NE-3280,NE-3240(1MF, AC2300V)
86	A61073030GP	PARTS BRACKET B	1	
87	ANE6142-F60	MICROSWITCH	2	△ NE-3280,NE-2180 V-15G-3C26(SECONDARY INTERLOCK SWITCH)
87	A61423030GP	MICROSWITCH	2	△ NE-3240,NE-2140 (A20G7-3C108) SECONDARY INTERLOCK SWITCH
88	A61424L0AG	MICROSWITCH	2	△ V-15G-3C26(PRIMARY INTERLOCK SWITCH)
88	A61424L0AG	MICROSWITCH	2	△ V-15G-3C26(PRIMARY INTERLOCK SWITCH)
89	A6144-3280	ANTENNA MOTOR	2	△ LOWER(2.5W)
89	A6144-3280	ANTENNA MOTOR	2	△ LOWER(2.5W)
90	A61446030AP	ANTENNA MOTOR	2	△ UPPER(2.5W)
91	A61454000AP	THERMAL CUTOUT	1	△ FOR OVEN
92	A61454050AP	THERMAL CUTOUT	2	△ FOR ANTENNA MOTOR
92	A61454050AP	THERMAL CUTOUT	2	△ FOR ANTENNA MOTOR
93	A61454210AP	THERMAL CUTOUT	4	△ FOR MAGNETRON
93	A61454210AP	THERMAL CUTOUT	4	△ FOR MAGNETRON
93	A61454210AP	THERMAL CUTOUT	4	△ FOR MAGNETRON

Ref. No.	Part No.	Part Name & Description	Pcs/Set	Remarks
93	A61454210AP	THERMAL CUTOOUT	4	△ FOR MAGNETRON
94	ANE61522QOBP	SOCKET	1	△
95	A61583030GP	DOOR SWITCH A	1	△ RIGHT (MONITOR SWITCH)
96	A61583050GP	DOOR SWITCH B	1	△ LEFT (MONITOR SWITCH)
97	A61703030GP	INSULATION SHEET B	1	
98	A6202-3280	DIODE, SI	4	
98	A6202-3280	DIODE, SI	4	
99	A62303580GP	FUSE	2	△ NE-3280 (20A)
99	A62303030EP	FUSE	1	△ NE-3240, NE-2140 (20A)
99	A62303A60BP	FUSE	1	△ NE-2180 (30A)
100	A62316010BP	FUSE HOLDER	6	NE-3280, NE-3240, NE-2140
100	A62316000GP	FUSE HOLDER	2	NE-2180
101	A62383030GP	SPACER	2	
101	A62383030GP	SPACER	2	
102	XYN5+C8BN	SCREW	2	NE-3280 (5X8) FOR NOISE FILTER
103	A64083040AP	WASHER	2	
103	A64083040AP	WASHER	2	
104	A65313030GP	SWITCH HOLDER	1	
105	ANE64086Q0AP	WASHER	1	
106	A65513030GP	H.V.T.MOUNTING	2	
106	A65513030GP	H.V.T.MOUNTING	2	
107	A65613030GP	BUZZER CASE	1	
108	A66623170GP	EARTH SPACER	1	
109	A65953170GP	FUSE B	1	△ NE-3280, NE-2180 (1.25A)
109	A65963030GP	FUSE B	1	△ NE-3240, NE-2140 (3A)
110	A66033030GP	OVEN LAMP BRACKET	1	
111	A66263040AP	THERMAL CUTOOUT MOUNT	2	
112	A692Y3560GP	NOISE FILTER (U)	1	△ NE-2140
112	A692Y3A40BP	NOISE FILTER (U)	1	△ NE-3280
112	A692Y3A60BP	NOISE FILTER (U)	1	△ NE-2180
112	A692Y3A50EU	NOISE FILTER (U)	1	△ NE-3240
113	XWC4BPN	WASHER		
113	XWC4BPN	WASHER		
114	A83613030GP	SWITCH SPACER		
115	A910A3A40BP	AC CORD W/OUT PLUG (U)	1	△ NE-3280
115	A910A3A50EU	AC CORD W/PLUG (U)	1	△ NE-3240
115	A910A3A60BP	AC CORD W/OUT PLUG (U)	1	△ NE-2180
115	A910A3560GP	AC CORD W/ PLUG (U)	1	△ NE-2140
116	XTC4+10FC	SCREW	1	4X10 (FOR ESCUTCHEON BASE)
117	XYN4+F18S	SCREW	4	4X18 (FOR DOOR HOOK B)
117	XYN4+F18S	SCREW	4	4X18 (FOR DOOR HOOK B)
118	XYN4+F12S	SCREW	4	4X12 (FOR DOOR SWITCH)
118	XYN4+F12S	SCREW	4	4X12 (FOR DOOR SWITCH)
119	ANE9080-730	CLIP (YELLOW)	2	NE-2180, NE-2140
119	ANE9080-730	CLIP (YELLOW)	3	NE-3280, NE-3240
119	ANE9080-730	CLIP (YELLOW)	2	NE-2180, NE-2140
119	ANE9080-730	CLIP (YELLOW)	2	NE-2180, NE-2140
119	ANE9080-730	CLIP (YELLOW)	2	NE-2180, NE-2140
120	ANE90828U0AP	CLIP (BLACK)	2	
120	ANE90828U0AP	CLIP (BLACK)	2	
121	ANE9082930AP	CLIP	8	
121	ANE9082930AP	CLIP	8	
121	ANE9082930AP	CLIP	8	
121	ANE9082930AP	CLIP	8	
121	ANE9082930AP	CLIP	8	
121	ANE9082930AP	CLIP	8	
122	A98363030GP	CASE	1	
122	A98363030GP	CASE	1	
122	A98363030GP	CASE	1	
123	XNG4EVS	NUT	1	NE-3280 (FOR CORD EARTH)
124	XST4+6VS	SCREW	8	4X6 (FOR ANTENNA)
124	XST4+6VS	SCREW	8	4X6 (FOR ANTENNA)
124	XST4+6VS	SCREW	8	4X6 (FOR ANTENNA)
124	XST4+6VS	SCREW	8	4X6 (FOR ANTENNA)
124	XST4+6VS	SCREW	8	4X6 (FOR ANTENNA)
124	XST4+6VS	SCREW	8	4X6 (FOR ANTENNA)
125	XTC4+10BC	SCREW	9	4X10 (FOR CABINET BODY LAMP COVER SASH)
125	XTC4+10BC	SCREW	9	4X10 (FOR CABINET BODY LAMP COVER SASH)
125	XTC4+10BC	SCREW	9	4X10 (FOR CABINET BODY LAMP COVER SASH)
125	XTC4+10BC	SCREW	9	4X10 (FOR CABINET BODY LAMP COVER SASH)
125	XTC4+10BC	SCREW	9	4X10 (FOR CABINET BODY LAMP COVER SASH)
125	XTC4+10BC	SCREW	9	4X10 (FOR CABINET BODY LAMP COVER SASH)
125	XTC4+10BC	SCREW	9	4X10 (FOR CABINET BODY LAMP COVER SASH)
126	XTC4+12BK	SCREW	3	4X12 (FOR BASE)
127	XTEANE5+10B	SCREW	4	5X10 (FOR ROLLER BRACKET)

Ref. No.	Part No.	Part Name & Description	Pcs/Set	Remarks
127	XTEANE5+10B	SCREW	4	5X10 (FOR ROLLER BRACKET)
128	XTWANE4+10RU	SCREW	8	4X10 (FOR LOWER MAGNETRON)
128	XTWANE4+10RU	SCREW	8	4X10 (FOR LOWER MAGNETRON)
128	XTWANE4+10RU	SCREW	8	4X10 (FOR LOWER MAGNETRON)
128	XTWANE4+10RU	SCREW	8	4X10 (FOR LOWER MAGNETRON)
129	XTWA4+12CFN	SCREW	1	NE-3280 (FOR CORD EARTH)
130	XWA4BV	WASHER	1	NE-3280 (FOR CORD EARTH)
131	XWA5BV	WASHER	1	NE-3280 (FOR CORD EARTH)
132	ANE0961000ZL	CUSHION RUBBER D	2	
132	ANE0961000ZL	CUSHION RUBBER D	2	
133	ANE0963000AS	CUSHION RUBBER D	2	
134	A10493030GP	CUSHION RUBBER	2	
134	A10493030GP	CUSHION RUBBER	2	
135	A18593560GP	SHELF SUPPORT	2	
136	A91433040AP	CLIP A	3	NE-2180,NE-2140
136	A91433040AP	CLIP A	1	NE-3280,NE-3240
136	A91433040AP	CLIP A	3	NE-2180,NE-2140
137	XNW5EFN	NUT	2	FOR SHELF SUPPRT
137	XNW5EFN	NUT	2	FOR SHELF SUPPRT
138	XWG5BV	WASHER	2	FOR SHELF SUPPRT
138	XWG5BV	WASHER	2	FOR SHELF SUPPRT
139	XWNANE65GV	SPACER	1	FOR BACK PANEL COVER C
140	XYE6+F20F	SCREW	1	6X20 (FOR BACK PANEL COVER C)
141	XTT4+8E	SCREW	1	4X8 (FOR BACK PANEL COVER C)
142	XYEANE5+C16T	SCREW	8	5X16 (FOR UPPER MAGNETRON)
142	XYEANE5+C16T	SCREW	8	5X16 (FOR UPPER MAGNETRON)
142	XYEANE5+C16T	SCREW	8	5X16 (FOR UPPER MAGNETRON)
142	XYEANE5+C16T	SCREW	8	5X16 (FOR UPPER MAGNETRON)
143	A30183030GP	DOOR KEY A	2	
143	A30183030GP	DOOR KEY A	2	
144	A80163060GP	CUSHION SPACER	1	
145	A02433560GP	TERMINAL LABEL	1	NE-3240,NE-2140
146	A608E3560GP	P.C. BOARD Q	1	NE-3280
147	ANE0962000ZE	CUSHION RUBBER D	2	
148	XTWANE3+8EX	SCREW	4	3X8 (FOR FOOT)
148	XTWANE3+8EX	SCREW	4	3X8 (FOR FOOT)
148	XTWANE3+8EX	SCREW	4	3X8 (FOR FOOT)
148	XTWANE3+8EX	SCREW	4	3X8 (FOR FOOT)
148	XTWANE3+8EX	SCREW	4	3X8 (FOR FOOT)
148	XTWANE3+8EX	SCREW	4	3X8 (FOR FOOT)
149	ANE6004P60GN	POWER RELAY	1	△ NE-3240,NE-2140
150	A60823030GP	POWER RELAY BRACKET	1	NE-3240,NE-2140
151	ANE6082P10GN	POWER RELAY BRACKET	1	NE-3240,NE-2140

NOTE: Please order name label together.

20 DOOR ASSEMBLE

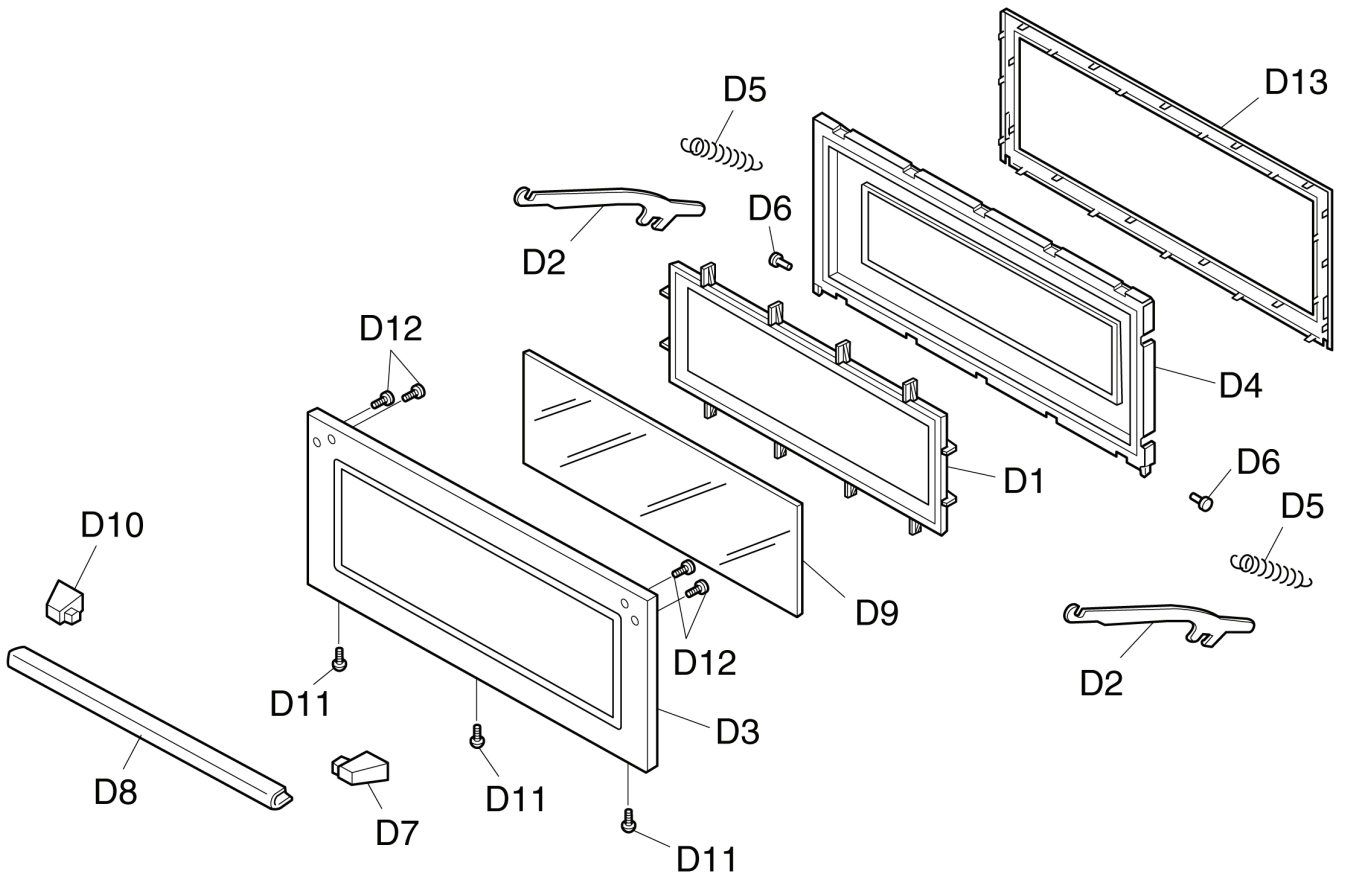

(S-3A4 BPQ)

Ref. No.	Part No.	Part Name & Description	Pcs/Set	Remarks
D1	A30033030GP	DOOR FRAME	1	
D2	A30043030GP	DOOR ARM	2	
D2	A30043030GP	DOOR ARM	2	
D3	A301A3030GP	DOOR A	1	
D4	A302K3030GP	DOOR E(U)	1	
D5	ANE3009P00RN	DOOR SPRING	2	
D5	ANE3009P00RN	DOOR SPRING	2	
D6	ANE3036P00RN	DOOR ARM PIN	2	
D6	ANE3036P00RN	DOOR ARM PIN	2	
D7	A30703030GP	HANDLE PIECE A	1	
D8	A31343030GP	HANDLE PIECE B	1	
D9	A31463030GP	DOOR SCREEN B	1	
D10	A31473030GP	HANDLE SHEET C	1	
D11	XTC4+10BC	SCREW	3	4X10
D11	XTC4+10BC	SCREW	3	4X10
D11	XTC4+10BC	SCREW	3	4X10
D12	XYEANE4+C16T	SCREW	4	4X16
D12	XYEANE4+C16T	SCREW	4	4X16
D13	A30853030GP	DOOR C	1	

21 ESCUTCHEON BASE ASSEMBLE

NE-3240,NE-2140

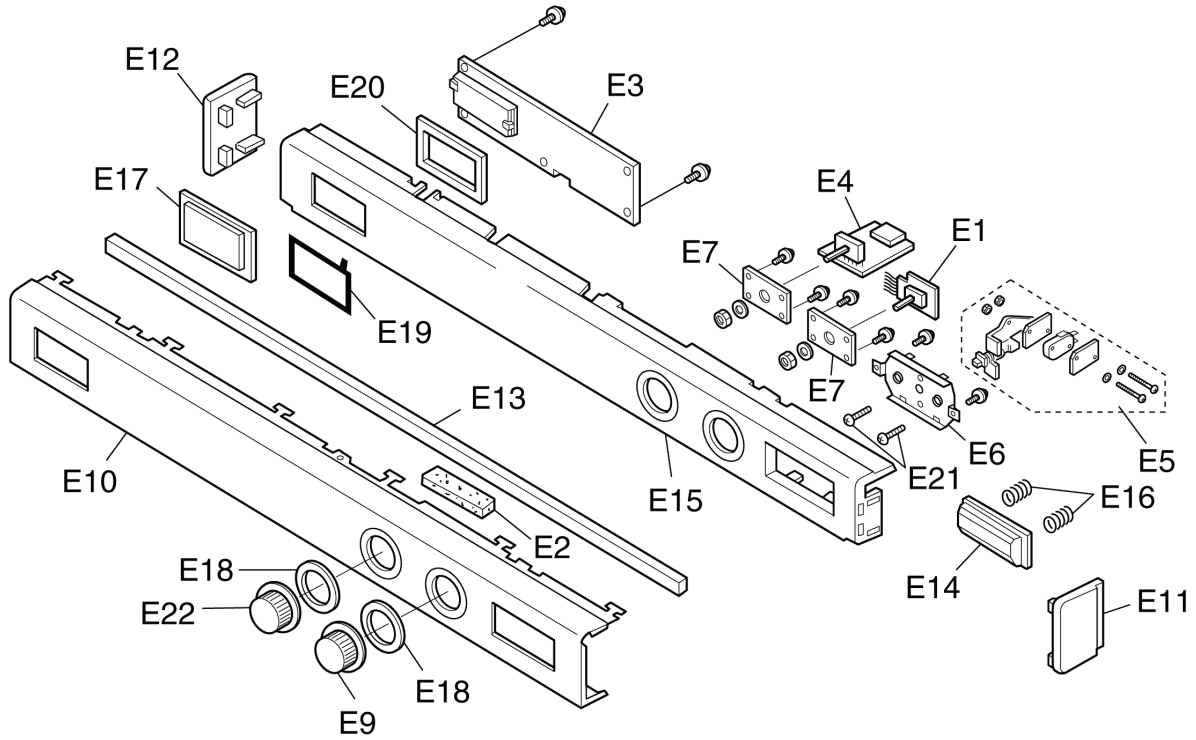

(S-3A4 BPQ)

NE-3280,NE-2180

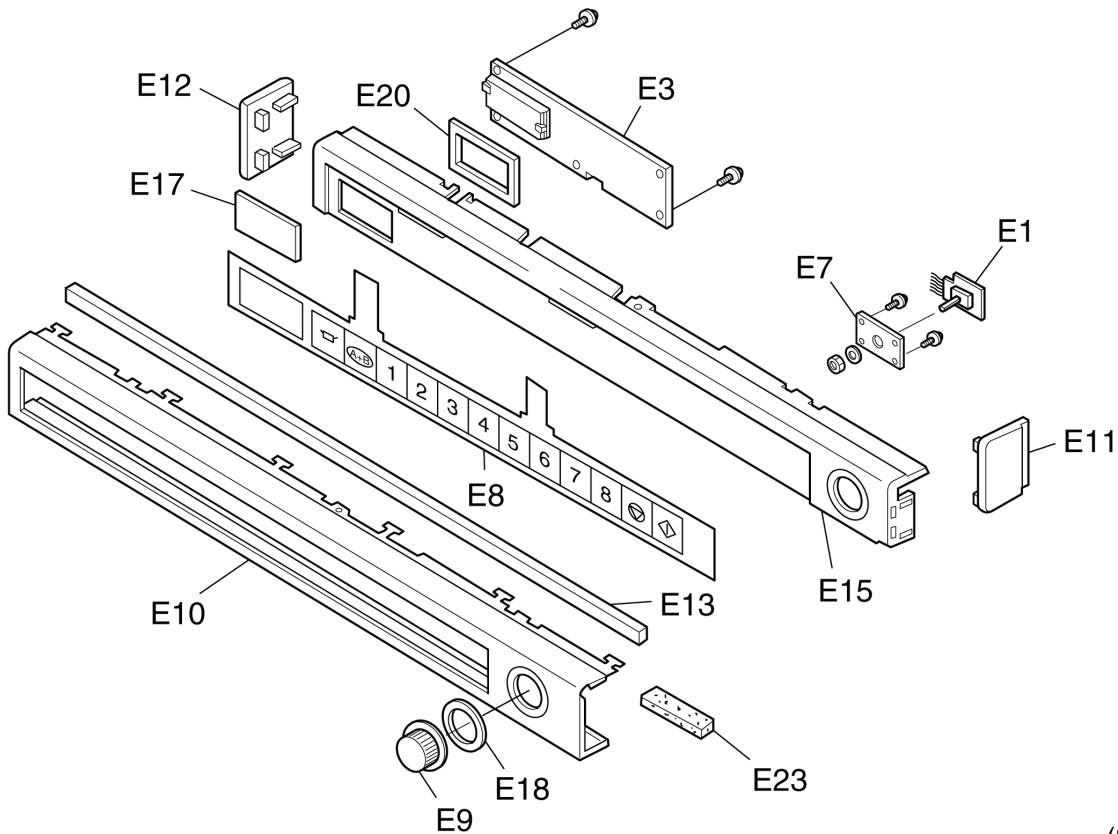

(S-3A4 BPQ)

Ref. No.	Part No.	Part Name & Description	Pcs/Set	Remarks
E1	A03613560GP	TIMER	1	
E1	A03613560GP	TIMER	1	
E2	ANE1062-8U0	CUSHION RUBBER B	1	NE-3240,NE-2140
E3	A603L3560GP	D.P.CIRCUIT (U)	1	△ NE-3240 RTL (W/COMPONENT)
E3	A603L3590GP	D.P.CIRCUIT (U)	1	△ NE-3280,NE-2180 RTL (W/COMPONENT)
E3	A603L3A70EU	D.P.CIRCUIT (U)	1	△ NE-2140 RTL (W/COMPONENT)
E4	A608C2560GP	POWER SELECT SWITCH	1	NE-3240,NE-2140
E5	ANE610EP00RN	START SWITCH	1	NE-3240,NE-2140
E6	A61623030GP	START SWITCH BRACKET	1	NE-3240,NE-2140
E7	A63433030GP	TIMER BRACKET	2	NE-3240,NE-2140
E7	A63433030GP	TIMER BRACKET	1	NE-3280,NE-2180
E7	A63433030GP	TIMER BRACKET	2	NE-3240,NE-2140
E8	A64793590GP	MEMBRANE SWITCH	1	△ NE-3280,NE-2180
E9	A800D3060GP	TIMER KNOB	1	
E9	A800D3060GP	TIMER KNOB	1	
E10	A800I3030GP	ESCUTCHEON A	1	NE-3240,NE-2140
E10	A800I3060GP	ESCUTCHEON A	1	NE-3280,NE-2180
E11	A80023030GP	ESCUTCHEON B	1	
E11	A80023030GP	ESCUTCHEON B	1	
E12	A80063030GP	ESCUTCHEON D	1	
E12	A80063030GP	ESCUTCHEON D	1	
E13	A80163030GP	ESCUTCHEON SPACER	1	
E13	A80163030GP	ESCUTCHEON SPACER	1	
E14	ANE8024P00RN	COOK BUTTON	1	NE-3240,NE-2140
E15	A80343030GP	ESCUTCHEON BASE	1	NE-3240,NE-2140
E15	A80343060GP	ESCUTCHEON BASE	1	NE-3280,NE-2180
E16	ANE8037P00RN	COOK BUTTON SPRING	2	NE-3240,NE-2140
E17	A81263030GP	SMOKE PANEL	1	NE-3240,NE-2140
E17	A81263060GP	SMOKE PANEL	1	NE-3280,NE-2180
E18	A82873030GP	SPACER A	2	NE-3240,NE-2140
E18	A82873030GP	SPACER A	1	NE-3280,NE-2180
E18	A82873030GP	SPACER A	2	NE-3240,NE-2140
E19	A83373560GP	ESCUTCHEON SHEET	1	NE-3240,NE-2140
E20	A83423030GP	CUSHION RUBBER B	1	NE-3240,NE-2140
E20	A83423060GP	CUSHION RUBBER B	1	NE-3280,NE-2180
E21	XYN4+C8S	SCREW	2	NE-3240,NE-2140 (4X8)
E22	A800D3030GP	TIMER KNOB	1	NE-3240,NE-2140
E23	ANE0911000AB	CUSHION RUBBER B	1	NE-3280,NE-2180

22 PACKING AND ACCESSORIES

Cut into three parts when packing.

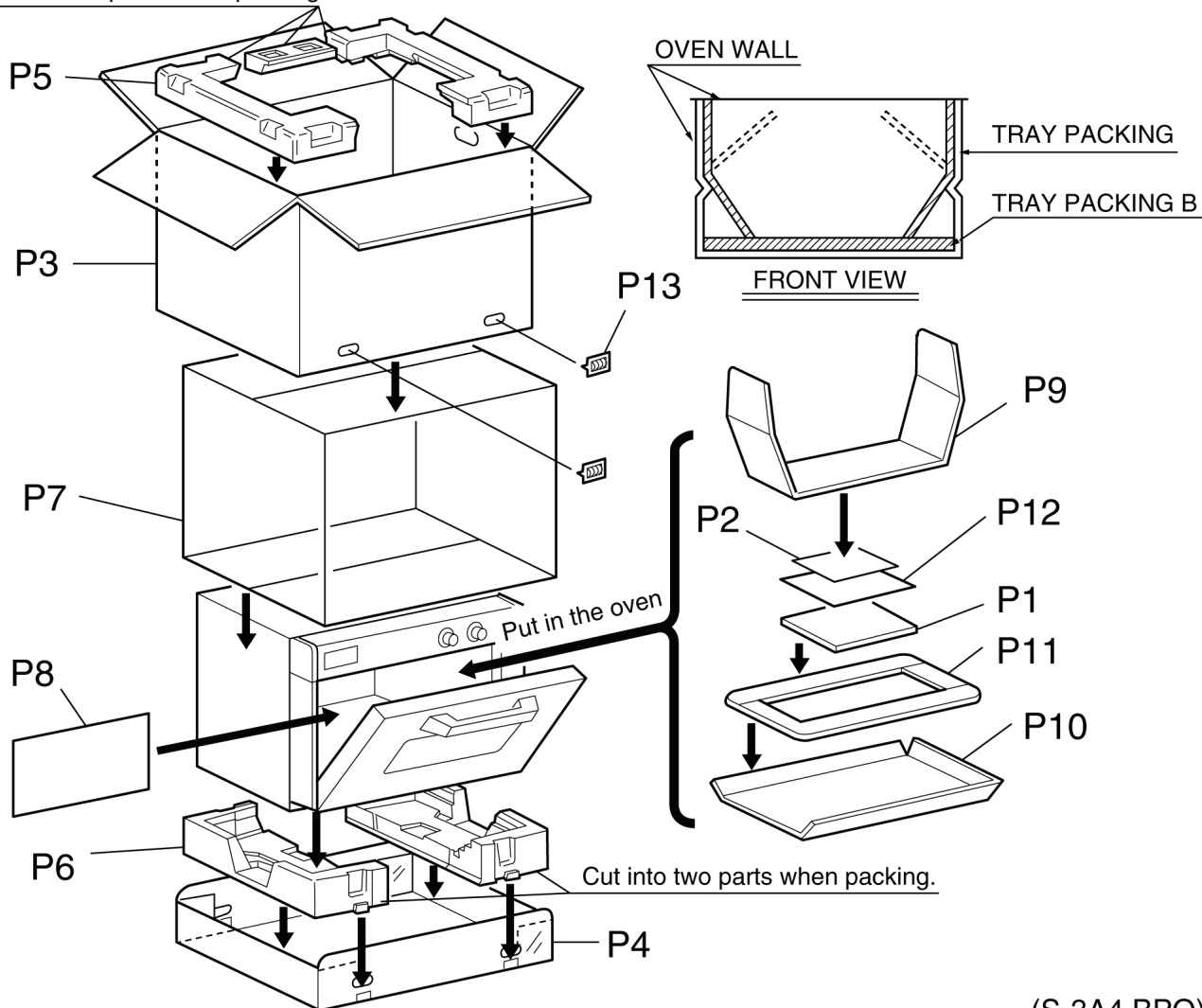

(S-3A4 BPQ)

Ref. No.	Part No.	Part Name & Description	Pcs/Set	Remarks
P1	A00033A40BP	INSTRUCTION BOOK	1	NE-3280,NE-2180
P1	A00033A50EU	INSTRUCTION BOOK	1	NE-3240,NE-2140
P2	A01723560BP	CAUTION LABEL	1	
P3	A01023A60BP	PACKING CASE, PAPER	1	NE-2180
P3	A01023A70EU	PACKING CASE, PAPER	1	NE-2140
P3	A01023A40BP	PACKING CASE, PAPER	1	NE-3280
P3	A01023A50EU	PACKING CASE, PAPER	1	NE-3240
P4	A01033030GP	BOTTOM CASE	1	
P5	A01043030GP	UPPER FILLER	1	
P6	A01053030GP	LOWER FILLER	1	
P7	A01063040AP	VINYL COVER	1	
P8	A01073030GP	DOOR SHEET	1	
P9	A01083030GP	TRAY PACKING	1	
P10	A01173030GP	TRAY PACKING B	1	
P11	A012D3050GP	SHELF B	1	
P12	A04203590BP	OPERATING GUIDE	1	NE-3280,NE-2180
P13	HP-601W	FASTENER	4	

23 WIRING MATERIAL

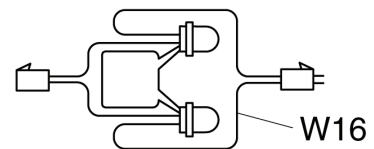
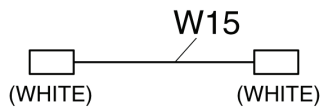
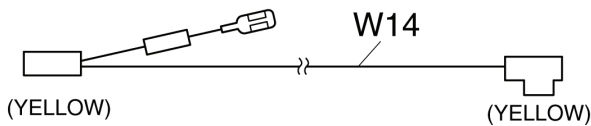
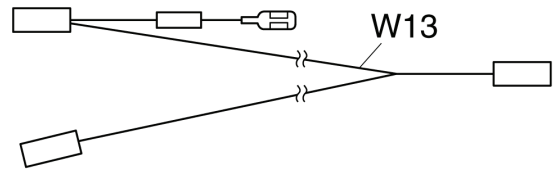
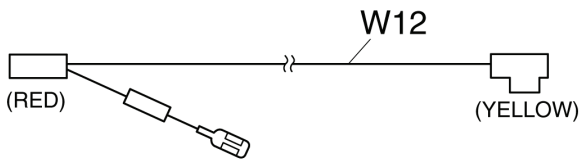
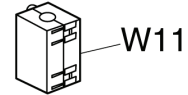
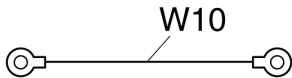
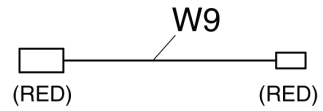
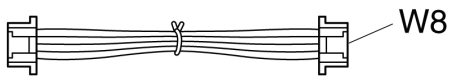
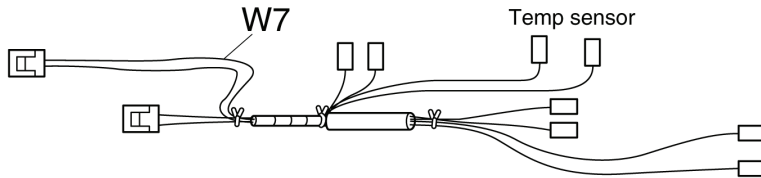
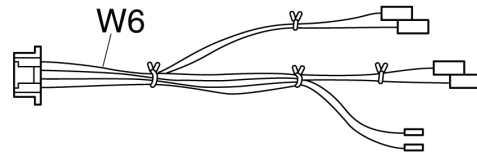
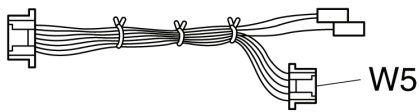
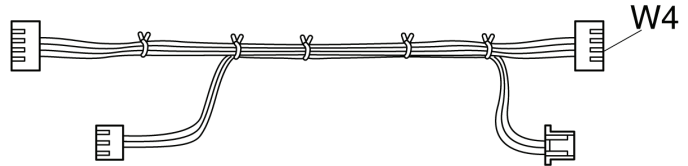
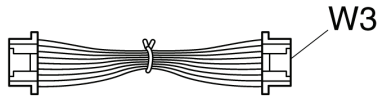
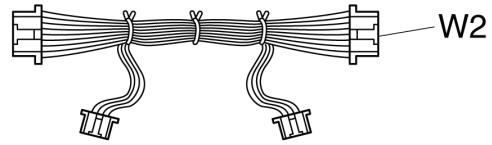
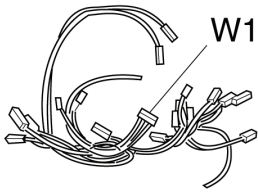

(S-3A4 BPQ)

NE-2180,NE-2140

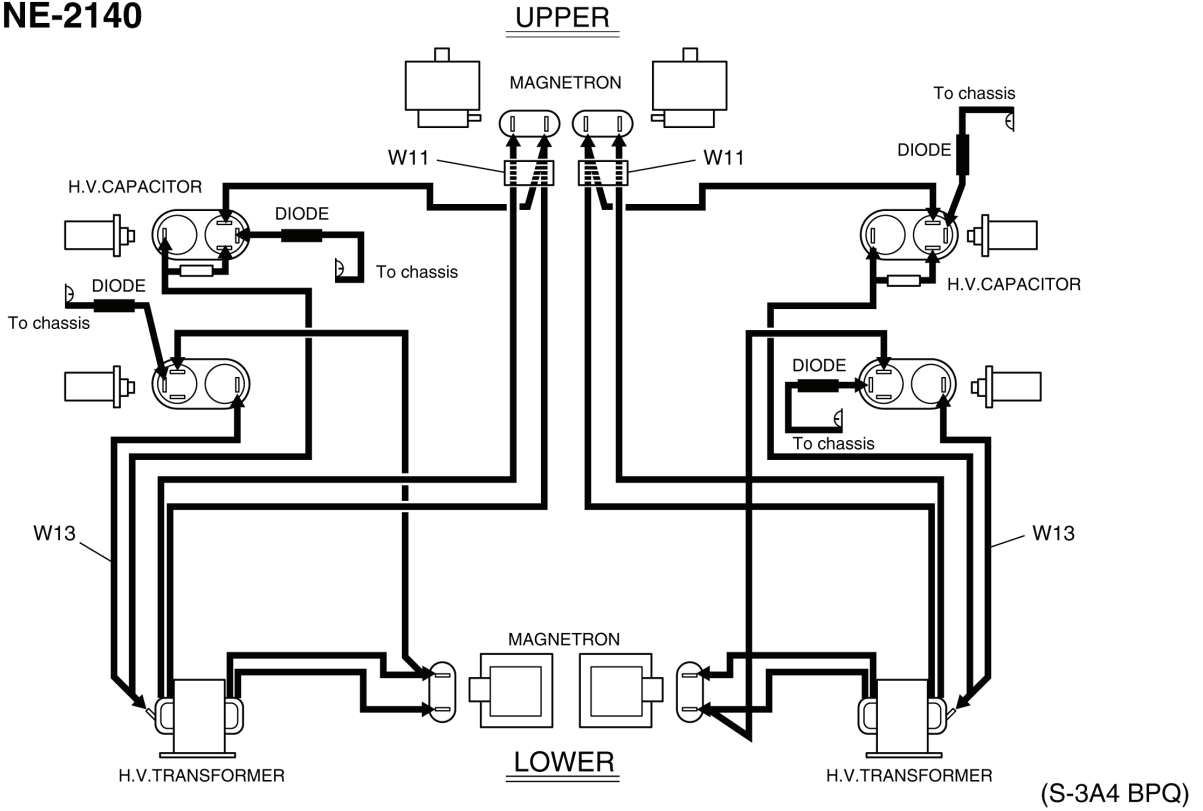

NE-3280,NE-3240

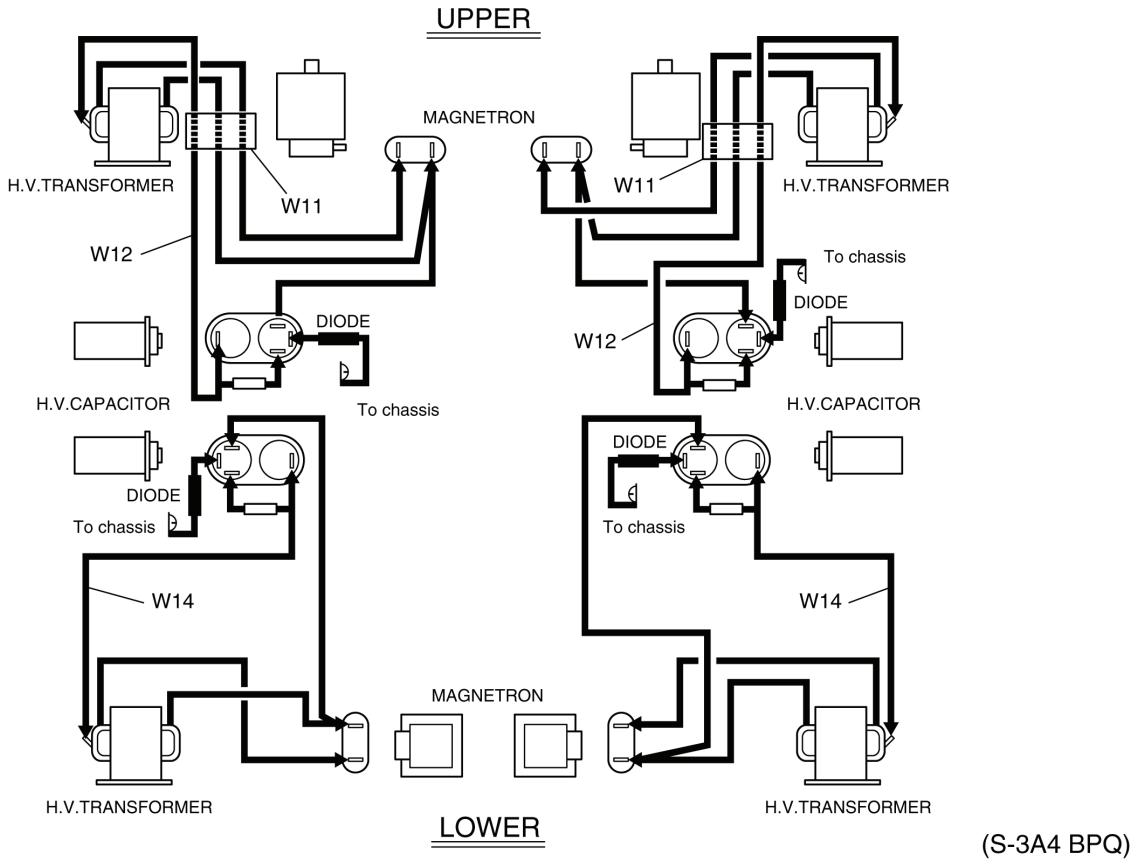

Ref. No.	Part No.	Part Name & Description	Pcs/Set	Remarks
W1	A030A3560BP	LEAD WIRE HARNESS	1	NE-3280
W1	A030A3580GP	LEAD WIRE HARNESS	1	NE-2180
W1	A030A3A50EU	LEAD WIRE HARNESS	1	NE-3240
W1	A030A3A70EU	LEAD WIRE HARNESS	1	NE-2140
W2	A03603560GP	LEAD WIRE	1	
W3	A03623560GP	LEAD WIRE	1	
W4	A03633560GP	LEAD WIRE	1	
W5	A03643560GP	LEAD WIRE	1	NE-3240,NE-2140
W6	A03653560GP	LEAD WIRE	1	
W7	A03693560GP	LEAD WIRE	1	
W8	A03703560GP	LEAD WIRE	1	
W9	A03723A60BP	LEAD WIRE	1	NE-2180
W10	A03813030GP	LEAD WIRE	2	NE-3240,NE-2140
W11	A50966520UP	FERRITE CORE	2	NE-2140
W11	A50966520UP	FERRITE CORE	4	NE-3280,NE-3240,NE-2180
W12	A606W3560GP	PROTECTOR DIODE B	2	NE-3280,NE-3240
W13	A606V3580GP	PROTECTOR DIODE	2	NE-2180,NE-2140
W14	A606V3560GP	PROTECTOR DIODE	2	NE-3280,NE-3240
W15	A03733560GP	LEAD WIRE	1	NE-3240,NE-2140
W16	A03753030GP	NOISE KILLER	1	NE-3240

Ref. No.	Part No.	Part Name & Description	Pcs/Ser	Remarks
REF NO.76 P.C.BOARD B (U)				
	AEGHPUG3640		1	△
	XYN3+F8S6		1	3X8
	2SD2012		1	
	ERDS2TJ163T		1	NE-2180,NE-2140 (16KΩ,1/4W,5%)
C250	ECA1HHG222E		1	2200MF/50V
CN250	AEEMMD1FF09W		1	9PIN
CN251	AEEMMD7FF11N		1	11PIN
CN252	AEEMMD04907W		1	7PIN
CN254	AEEMMD01F05W		1	5PIN
D250, D251, D252, D253, D254, D255, D256, D257, D258, D259, D260, D261, D262, D263, D264, D265, D267, D269, D271, D273	MA196 - (TA5)	DIODE SI	20	
IC250, IC251, IC252, IC253	AEICPS2505	IC	4	NE-3280
IC250, IC253	AEICPS2505	IC	2	NE-2180
JPR250	ERDS2TJ622T	CARBON FILM RESISTOR	1	NE-3280 (6.2KΩ,1/4W,5%)
JPR250	ERDS2TJ163T	CARBON FILM RESISTOR	1	NE-2180 (16KΩ,1/4W,5%)
Q251	2SD637-PQRS	TRANSISTOR SI	1	
R250	ERDS2TJ332T	CARBON FILM RESISTOR	1	3.3KΩ,1/4W,5%
R251, R252, R253, R254, R255, R256, R257, R258	ERDS1TJ104T	CARBON FILM RESISTOR	8	NE-3280
R251, R252, R257, R258	ERDS1TJ104T	CARBON FILM RESISTOR	4	NE-2180,NE-2140 (100KΩ,1/2W,5%)
R259, R260	ERF15ZXJ240	RESISTOR	2	24Ω,15W,5%
R261	ERDS2TJ684T	CARBON FILM RESISTOR	1	680KΩ,1/4W,5%
RY1	AEBG5B18P-1	POWER RELAY	1	△ G5B-1-ER18 (18V)
RY2, RY3, RY9, RY11, RY14, RY16	AEG5J1EM18B	POWER RELAY	7	△ NE-2180,NE-2140 (G5J-1-TP-M-ER18)
RY2, RY3, RY5, RY7, RY9, RY11, RY12, RY13, RY14, RY15, RY16	AEG5J1EM18B	POWER RELAY	11	△ NE-3280 (G5J-1-TP-M-ER18)
	AEG5J1EM18B	POWER RELAY	13	△ NE-3240
REF NO.82 P.C.BOARD H(U)				
BZ	EFBRL37C20	BUZZER	1	3.7KHZ
CN551	AEEMMB00703R	CONNECTOR	1	3PIN
D551	MA196 - (TA5)	DIODE, SI	1	
Q551	2SD639-PQRS	TRANSISTOR SI	1	
R551	ERDS2TJ681T	CARBON FILM RESISTOR	1	680Ω,1/4W,5%

Ref. No.	Part No.	Part Name & Description	Pcs/Ser	Remarks
CN551	ERDS2TJ184T	CARBON FILM RESISTOR	1	180K Ω , 1/4W, 5%
CN551	ERDS2TJ103T	CARBON FILM RESISTOR	1	10K Ω , 1/4W, 5%
REF NO.112 NOISE FILTER (U)				
C1	ECQU2A224MNA	POLYESTER CAOACITOR	1	NE-3280 (0.22MF 250V)
C1, C6	ECQU2A224MNA	POLYESTER CAOACITOR	2	NE-3240, NE-2180, NE-2140 (0.22MF 250V)
C2, C3	ECKMNA472ME	CERAMIC CAPACITOR	2	Δ NE-2180 (0.0047MF 250V)
C2, C3	A6169A20GN	CAPACITOR	2	NE-3280 (0.022MF 250V)
CN1, CN3	A61663560BP	TERMINAL BOARD	2	NE-3280
CN9	AEEMMD00703W	CONNECTOR	1	3PIN
D1	ERZC10DK621F	VARISTOR	1	
D2, D3	ERZC10DK112R	VARISTOR	2	
F1, F2	A62316010BP	FUSE HOLDER	4	
F1, F2	A6116-1740	TERMINAL BOARD	2	NE-3280
F3	A62316000GP	FUSE HOLDER	2	
L1	A621A3A50EU	FILTER COIL	1	NE-3240
L1	A621A3560GP	FILTER COIL	1	NE-3280

24 DIGITAL PROGRAMMER CIRCUIT

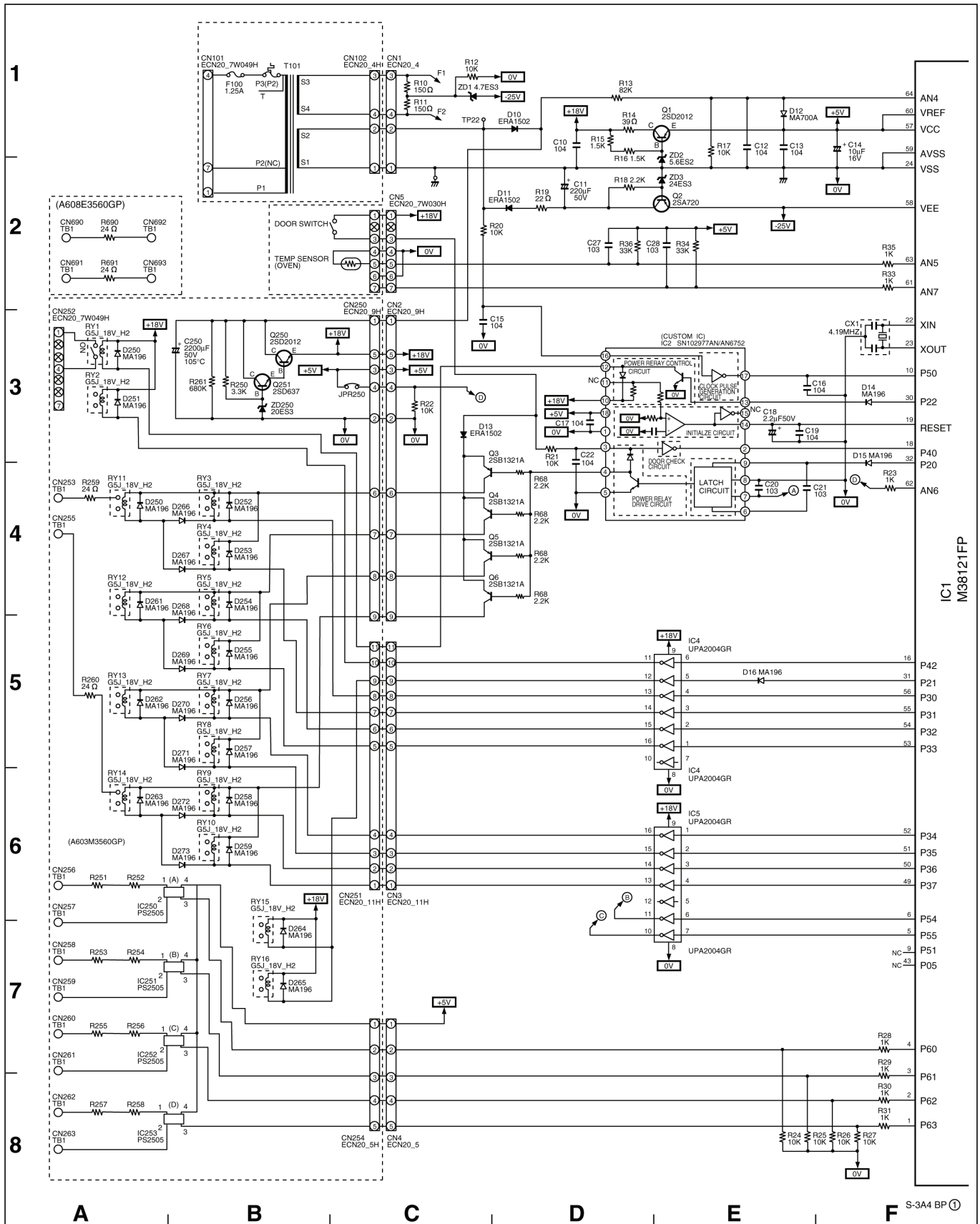

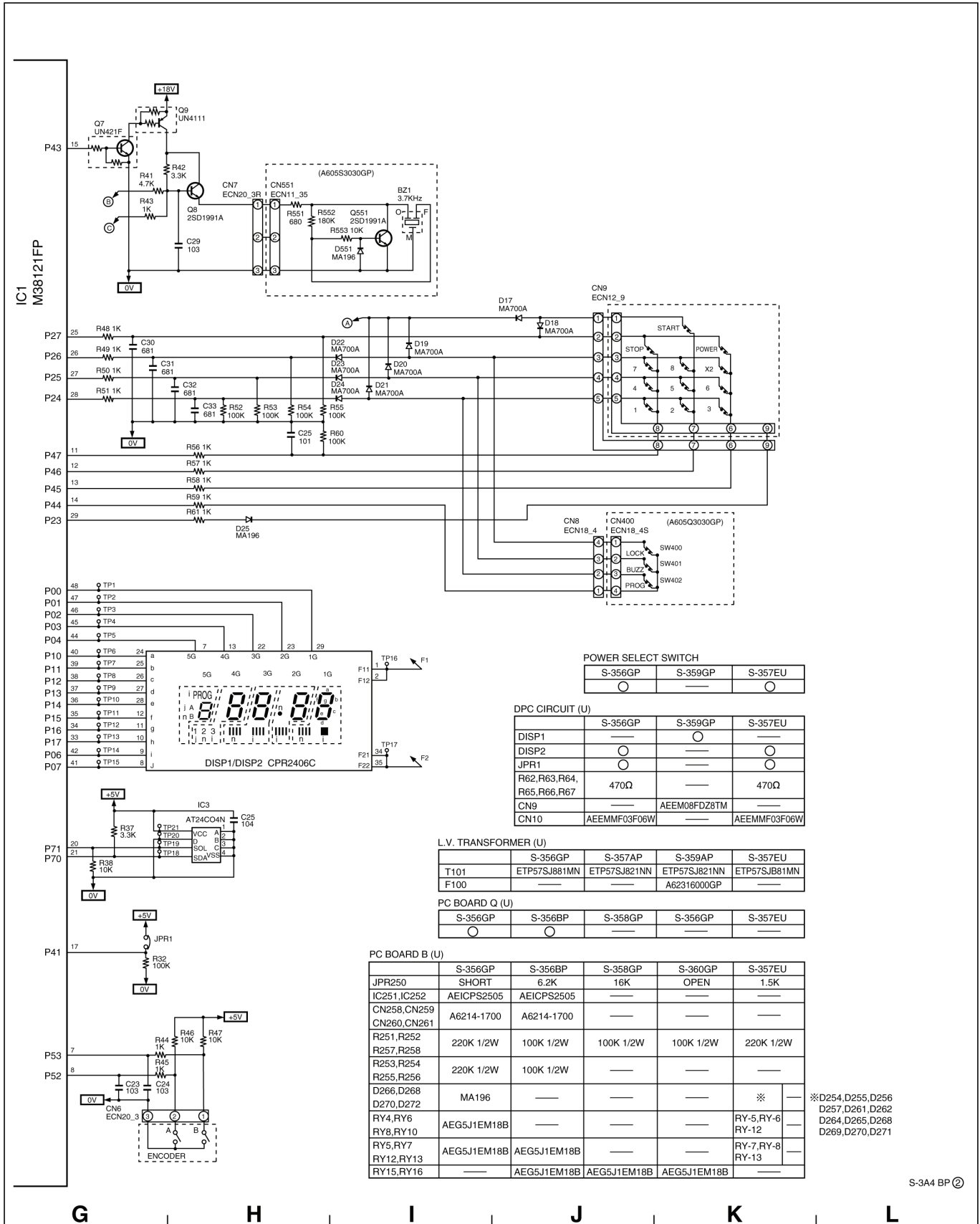

S-3A4 BP ②

25 DIGITAL PROGRAMMER CIRCUIT

PARTS LIST

Ref. No.	Part No.	Description	Pcs/set	Remarks
C10, 12, 13, 15, 16, 17, 19, 22, 26, 29	AECF50F104Z	CERAMIC CAPACITOR	10	0.1MF/50V
C11	ECA1HM221B	ELECTROLYTIC CAPACITOR,AL	1	220MF/50V
C14	ECEA1CKA100B	ELECTROLYTIC CAPACITOR,AL	1	10MF/16V
C18	ECEA1HKA2R2B	ELECTROLYTIC CAPACITOR,AL	1	2.2MF/50V
C20, C21, C23, C24, C27, C28	ECBT1E103ZF5	CERAMIC CAPACITOR	6	0.01MF/25V
C25	ECBT1H101KB5	CERAMIC CAPACITOR	1	0.0001MF/50V
C30, C31, C32, C33	ECBT1H681KB5	CERAMIC CAPACITOR	4	680PF
CN1	AEEMMF00F04W	CONNECTOR	1	4PIN
CN2	AEEMMD1FF09W	CONNECTOR	1	9PIN
CN3	AEEMMD7FF11N	CONNECTOR	1	11PIN
CN4	AEEMMF01F05W	CONNECTOR	1	5PIN
CN5	AEEMMD07D07W	CONNECTOR	1	7PIN
CN6	AEEMMF00703W	CONNECTOR	1	3PIN
CN7	AEEMMF00703R	CONNECTOR	1	3PIN RED
CN8	AEEMB04BP0K	CONNECTOR	1	4PIN
CN9	AEEM08FDZ0TN	CONNECTOR	1	
CX1	EFOGC4194T4	RESONATOR	1	4.19MHZ
D10, D11, D13	AEDNERA1502	DIODE, SI	3	1.0A
D12, D18, D22, D23, D24	MA700A - (TA)	DIODE, SI	5	MA700A 0.03A
D14, D15, D16, D17, D19, D20, D21, D25	MA196 - (TA5)	DIODE, SI	8	MA196 0.1A
DISP	A64563030GP	FLUORESCENT TUBE	1	CPR2406C
SPACER	A82843030GP	SPACER CUSHION	2	
IC1	AEIC38121472	IC	1	M38121
IC2	AEIC102977AN	IC	1	SN102977AN/AN6752
IC3	AEICAT24C04N	IC	1	AT24C04N
C4, C5	AEICU2004GR	IC	2	A2004G
Q1	2SD2012	TRANSISTOR, SI, 2W	1	3MHZ
Q2	2SA720PRTA	TRANSISTOR, SI, 400MW	1	200MHZ
Q3, Q4, Q5, Q6	2SB1321A	TRANSISTOR, SI, 600MW	4	200MHZ
Q7	UN421F	TRANSISTOR, SI, 300MW	2	
Q8	2SD1991A	TRANSISTOR, SI, 400MW	2	150MHZ
Q9	UN4111 - (TA)	TRANSISTOR, SI, 300MW	1	
R10, R11	ERDS2TJ151T	CARBON FILM RESISTOR	2	150 Ω , 1/4W, 5%
R12, 17, 20, 21, 22, 24, 25, 26, 27, 38, 39, 40, 46, 47	ERDS2TJ103T	CARBON FILM RESISTOR	14	10K Ω , 1/4W, 5%
R13	ERDS2TJ823T	CARBON FILM RESISTOR	1	82K Ω , 1/4W, 5%
R14	ERDS2TJ390T	CARBON FILM RESISTOR	1	39 Ω , 1/4W, 5%
R15, 16	ERDS2TJ152T	CARBON FILM RESISTOR	2	1.5K Ω , 1/4W, 5%
R18, R68X4	ERDS2TJ222T	CARBON FILM RESISTOR	5	2.2K Ω , 1/4W, 5%
R19	ERDS2TJ220T	CARBON FILM RESISTOR	1	22 Ω , 1/4W, 5%
R23, R28, R29, R33, R35, R45, R48, R51, R56, R57, R58, R59, R61	ERDS2TJ102T	CARBON FILM RESISTOR	19	1.0K Ω , 1/4W, 5%
R32, R52, R53, R54, R55, R60	ERDS2TJ104T	CARBON FILM RESISTOR	6	100K Ω , 1/4W, 5%
R34, R36	ERDS2TJ333T	CARBON FILM RESISTOR	2	33K Ω , 1/4W, 5%
R37, R42	ERDS2TJ332T	CARBON FILM RESISTOR	2	3.3K Ω , 1/4W, 5%
R41	ERDS2TJ472T	CARBON FILM RESISTOR	1	4.7K Ω , 1/4W, 5%
ZD1	AEDZ4R7ES3T1	ZENER DIODE, SI	1	RD4.7ES3
ZD2	AEDZ5R6ES2T1	ZENER DIODE, SI	1	RD5.6ES2
ZD3	AEDZ24ES3T1	ZENER DIODE, SI	1	RD24ES3